

---

# FLOW-TEK

## SERIES 40

### 1 Piece Reduced Port Ball Valves



Flow-Tek's Model S40 ball valves offer an economical, compact, one piece body design. The one piece body supplies maximum structural strength while minimizing the number of potential leak paths. Model S40 valve bodies are high quality investment cast 316 stainless steel.

S40 valves feature quarter turn operation, blowout proof stems and low operating torque.

The standard handle design is a locking lever or an optional oval handle is available for ease of operation or for safety applications.

Size	Pressure Rating	Temperature Range	End Connections	Body Material
1/4" to 2" 8mm to 50mm	1000 psi WOG 69 bar	-50°F to +450°F -46°C to +232°C	Threaded - NPT	Stainless Steel



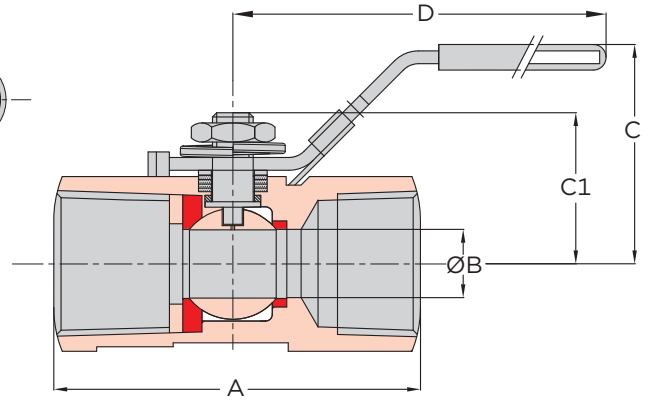
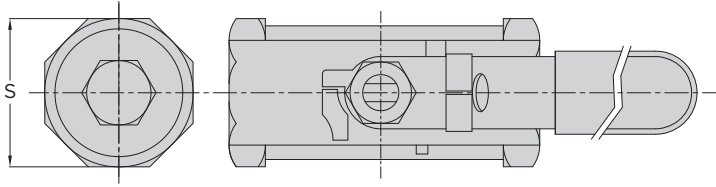

**Dimensions (inch)**

Size in	A	øB Port	C	C1	D	S	Cv	Weight lb
1/4	1.54	.20	1.22	.69	2.56	.67	1.6	.132
3/8	1.73	.27	1.42	.80	3.35	.83	3.1	.231
1/2	2.22	.36	1.61	1.02	3.74	.98	5.5	.375
3/4	2.32	.49	1.73	1.12	3.74	1.26	10	.551
1	2.80	.59	1.89	1.41	4.37	1.50	15.5	.915
1-1/4	3.07	.79	2.13	1.54	4.37	1.93	20	1.422
1-1/2	3.27	.98	2.56	1.81	5.59	2.09	37	1.753
2	3.94	1.26	2.83	2.05	5.59	2.56	60	2.744

**Dimensions (mm)**

Size mm	A	øB Port	C	C1	D	S	Cv	Weight Kg
8	39	5	31	17.5	65	17	1.6	.06
10	44	6.8	36	20.2	85	21	3.1	.10
15	56.5	9.2	41	26	95	25	5.5	.17
20	59	12.5	44	28.5	95	32	10	.25
25	71	15	48	35.8	111	38	15.5	.42
32	78	20	54	39	111	49	20	.65
40	83	25	65	46	142	53	37	.80
50	100	32	72	52	142	65	60	1.24

**PRESSURE/TEMPERATURE**

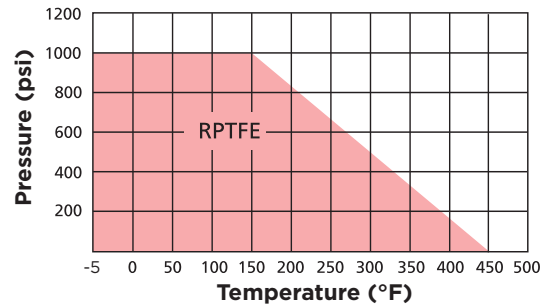

**COMPONENTS AND MATERIALS**

Item	Name	Material	Qty.
1	Body	ASTM A351   Gr CF8M	1
2	Body Insert	ASTM A351   Gr CF8M	1
3	Ball	SS316	1
4A	Seat	RPTFE	1
4B	Seat	RPTFE	1
5	Stem	SS316	1
7	Spring Washer	SS304	1
12	Thrust Washer	RPTFE	1
14	Stem Packing	RPTFE	1 set
25	Handle	SS304	1
26	Handle Nut	SS304	1
28	Handle Sleeve	Vinyl	1
29	Locking Device	SS304	1
41	Packing Ring	SS304	1

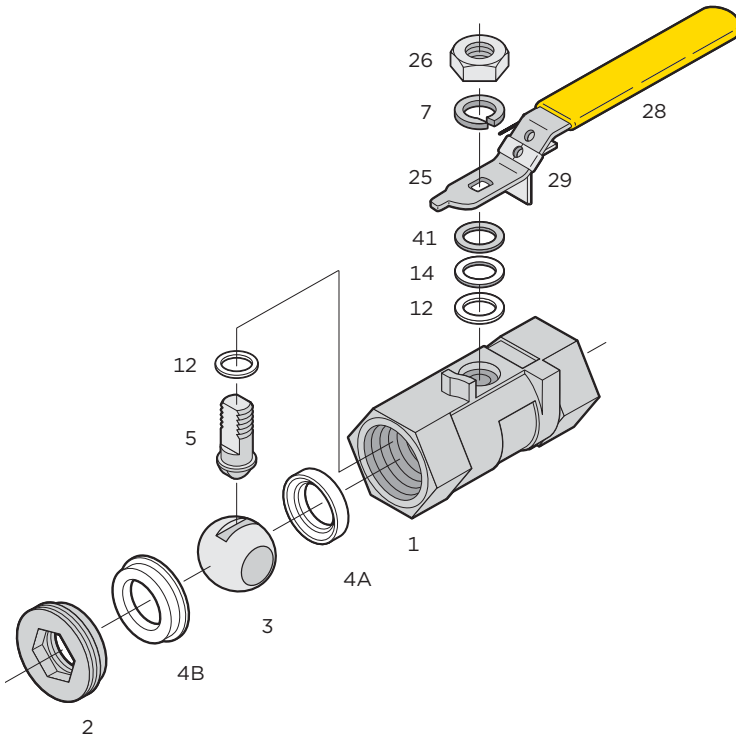

**TESTING AND STANDARDS**

- > All valves are tested in accordance with API 598.
- > Threaded End Connections meet ASME B1.20.1 NPT.
- > Vacuum service to 29 inches Hg. gauge.
- > Design Standard MSS-SP110, MSS-SP55, MSS-SP61