

FLOW-TEK SERIES 7000/8000

3-PIECE FULL PORT BALL VALVES

Installation, Operation, and Maintenance Manual

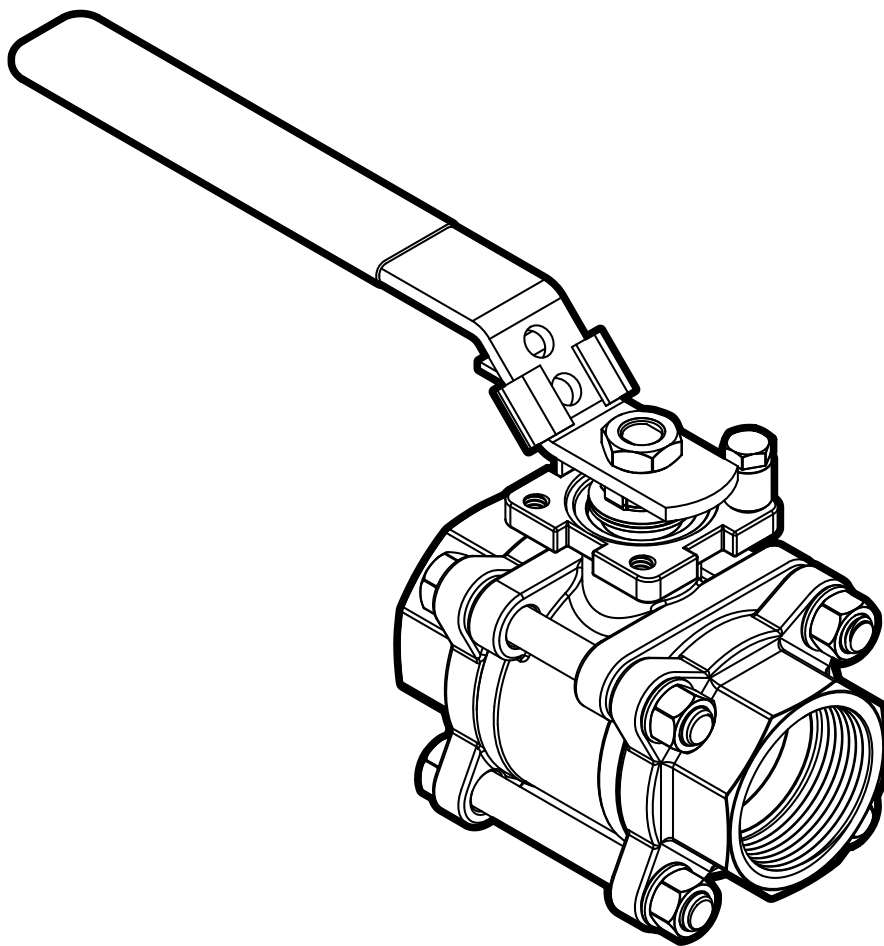

CONTENTS

1.0	DEFINITION OF TERMS	4
1.1	Safety Statements	4
2.0	GENERAL INFORMATION	5
2.1	Introduction	5
2.2	Use	5
2.3	Applicability	6
3.0	SAFETY INFORMATION	7
3.1	Protective Clothing	8
3.2	Service and Repair	8
3.3	Hazard-Free Use.	8
3.4	Qualified Personnel	9
4.0	PARTS IDENTIFICATION	10
4.1	Parts Callout - NPS ¼ to 2½ DN 8 to 65.	10
4.2	Parts List - NPS ¼ to 2½ DN 8 to 65	11
4.3	Parts Callout - NPS 3 and 4 DN 80 and 100	12
4.4	Parts List - NPS 3 and 4 DN 80 and 100	13
4.5	Parts Callout - NPS 6 and 8 DN 150 and 200	14
4.6	Parts List - NPS 6 and 8 DN 150 and 200	15
4.7	Parts Callout - NPS 10 and 12 DN 250 and 300	16
4.8	Parts List - NPS 10 and 12 DN 250 and 300	17
4.9	Spare Parts.	17
5.0	VALVE IDENTIFICATION	18
6.0	HANDLING REQUIREMENTS	19
6.1	Packed Valves	19
6.2	Unpacked Valves	19
6.3	Moving Valves	20
7.0	TRANSPORT AND STORAGE	22
7.1	Transport.	22
7.2	Short-Term Storage	22
7.3	Long-Term Storage	22
7.4	General Storage Requirements	23
8.0	INSTALLATION	24
8.1	Considerations.	24
8.2	Actuator Installation	24
8.3	Actuator Mounting	25
8.4	Installation of Threaded End Valves.	26
8.5	Installation of Extended Weld-End Valve.	27
8.6	Installation of Weld-end (Tank Bottom and Non-Extended) Valves	27
8.7	After Installation.	29

SERIES 7000/8000 3-PIECE FULL PORT BALL VALVE

Installation, Operation, and Maintenance Manual



9.0	OPERATION	31
10.0	MAINTENANCE AND REPAIR	32
10.1	Stem Seal Adjustment	32
10.2	Actuator Removal	32
10.3	Valve Removal from System and Cleaning Procedure.	33
10.4	Valve In-line Service.	34
10.5	Valve Disassembly.	35
10.6	Visual Inspection	36
10.7	Valve Assembly Procedures NPS ¼ - 2 DN 8 - 50.	37
10.8	Valve Assembly Procedures NPS 3 - 4 DN 80 - 100.	38
10.9	Valve Assembly Procedures NPS 6 and 8 DN 150 and 200	40
10.10	Valve Assembly Procedures NPS 10 and 12 DN 250 and 300.	42
11.0	REPAIR KITS.	44
12.0	TROUBLESHOOTING.	45
13.0	RETURN MERCHANDISE AUTHORIZATION.	46

**READ AND FOLLOW THESE INSTRUCTIONS CAREFULLY.
FOR THE LATEST IOM VERSION, VISIT BRAY.COM**

1.0 DEFINITION OF TERMS

All information within this manual is relevant to the safe operation and proper care of your Bray valve. Please understand the following examples of information used throughout this manual.

Specific instructions for non-standard materials of construction, temperature range, etc. should be referred to the factory.

1.1 Safety Statements

To prevent unwanted consequences, standard symbols and classifications are used as shown below:



DANGER

Indicates a potentially hazardous situation which, if not avoided, will result in death or serious injury.



WARNING

Indicates a potentially hazardous situation which, if not avoided, could result in death or serious injury.



CAUTION

Indicates a potentially hazardous situation which, if not avoided, could result in minor or moderate injury.



NOTICE

Used without the safety alert symbol, indicates a potential situation which, if not avoided, may result in an undesirable result or state, including property damage.

NOTE: Provides important information related to a procedure.

2.0 GENERAL INFORMATION

2.1 Introduction



NOTICE

Failure to follow these procedures and observe these notes, cautions and warnings including the use of non-OEM parts could lead to hazards and/or void product warranties, either expressed or implied.

These instructions cover Series 7000/8000 three piece and Tank Bottom Series TK7000/TK8000 soft seated valves.

The design features of this valve include three piece construction allowing ease of maintenance without special tools. These valves feature a “free floating” ball. The ball is not fixed, but is free to move with the line pressure. As a result of this feature, these valves are capable of tight shut off with flow in either direction regardless of the position of the valve in the line.

The downstream seat, opposite the pressurized side of a closed valve, must carry the load exerted by the line pressure on the ball, while the upstream seat is subject to little load or wear. Turning the valve end-for-end in the pipeline will increase useful seat life by dividing seat wear between the two seats.

The valve should be maintained as part of a preventative maintenance program and in accordance with Bray’s recommended pressure and temperature to ensure a long service life. During shipment, storage, and in operation, the valve should be fully open or fully closed (“open” is preferred for shipping and storage).

Additional product information (such as application data, engineering specifications, actuator selection, etc.) is available from your local Bray distributor or sales representative, or online at **BRAY.COM**.

For complete details on the latest product certifications, visit **BRAY.COM/Certifications**.

2.2 Use

The following instructions are designed to assist in the unpacking, installation, and maintenance as required for Bray ball valves. Product users and maintenance personnel should thoroughly review this manual prior to installing, operating, or performing any maintenance. In most cases, Bray valves, actuators, and accessories are designed for specific applications (e.g. with regard to medium, pressure and temperature). For this reason, they should not be used in other applications without first contacting the manufacturer.



WARNING

Before installing this equipment, confirm that it is suitable for the intended service. The identification tags describe the maximum allowable service conditions for this product. Be sure that the installation is protected by appropriate pressure control and safety devices to ensure that acceptable limits are not exceeded.

2.3 Applicability

The following instructions are applicable to the maintenance and installation of Bray ball valves. These instructions cannot claim to cover all details of all possible product variations, nor can they provide information for every possible example of installation, operation, or maintenance. This means that the instructions normally include only the directions to be followed by qualified personnel using the product for its defined purpose. If there are any uncertainties in this respect, particularly in the event of missing product related information, clarification must be obtained via the appropriate Bray sales office.

3.0 SAFETY INFORMATION



NOTICE

Failure to follow these procedures could affect product warranty.

Read completely and understand all instructions provided prior to beginning installation or maintenance.

Follow all instructions as described using the correct tools for the job.

Before installing this equipment, confirm that it is suitable for the intended service. The identification tags describe the maximum allowable service conditions for this product.

Be sure that the installation is protected by appropriate pressure control and safety devices to ensure that acceptable limits are not exceeded.



WARNING

Prior to servicing, remove actuation media and power and confirm there is no stored energy in the actuation such as compressed springs or trapped air before beginning service. Stored energy devices can cause serious injury if the energy is released without warning.

Confirm that line pressure has been removed and that there is no pressure trapped within the valve prior to beginning service. Do not attempt to remove any packing components or other fittings before confirming that pressure has been completely removed!



WARNING

Before working on valve being in service make sure that service media has been flushed and line is safe. Make sure that all applicable MSDS sheets are available. Follow all safety related procedures.

Do not begin service work without proper tools and protective safety measures.

The work area should be clear of obstructions and other safety hazards.



NOTICE

Before disassembly valve shall be cycled several times to assure there is no pressure trapped in body cavity.



WARNING

During the pressure test of reassembled valve follow all safety precautions to avoid possible injury. (Use of proper test equipment, correct parts assemblies, follow test procedures.)



WARNING

While line is under pressure DO NOT remove packing gland or any other valve parts.

3.1 Protective Clothing

Bray products are often used in critical applications (e.g. under extremely high pressures with dangerous, toxic, or corrosive mediums). When performing service, inspection, or repair operations, always ensure that the valve and the actuator are depressurized, the valve has been cleaned, and the valve is free of harmful substances. In such cases, pay particular attention to personal protection (e.g. protective clothing, gloves, glasses, etc.).

3.2 Service and Repair

To avoid possible injury to personnel or damage to products, safety terms must be strictly adhered to. Modifying this product, substituting non-factory parts, or using maintenance procedures other than those outlined in these Installation, Operation and Maintenance instructions could drastically affect performance, be hazardous to personnel and equipment, and may void existing warranties.

Apart from the operating instructions and the obligatory accident prevention directives valid in the country of use, all recognized regulations for safety and good engineering practices must be followed.

3.3 Hazard-Free Use



NOTICE

Failure to follow these procedures could affect product warranty.

This device left the factory in proper condition to be safely installed and operated in a hazard-free manner. The notes and warnings in this document must be observed by the user if this safe condition is to be maintained and hazard-free operation of the device assured.

Take all necessary precautions to prevent damage to the valve due to rough handling, impact, or improper storage. Do not use abrasive compounds to clean the valve, or scrape metal surfaces with any objects.

The control systems in which the valve is installed must have proper safeguards — to prevent injury to personnel, or damage to equipment — should failure of system components occur.

The upper limits of permitted pressure and temperature (depending on the housing and liner materials) must be observed. These limits are shown on the valve identification tag.

The valve must not be operated until the following documents have been observed:

- > Declaration on EU Directives (if applicable)
- > IOM Manual (supplied with the product).

3.4 Qualified Personnel



NOTICE

Failure to follow these procedures could affect product warranty.

A **qualified person** (in terms of this document) is one who is familiar with the installation, commissioning, and operation of the device, and who has appropriate qualifications, such as:

1. Is trained in the operation and maintenance of pressure equipment and systems in accordance with established safety practices.
2. Is trained in the operation and maintenance of electrical equipment and systems in accordance with established safety practices.
3. Is trained or authorized to energize, de-energize, ground, tag, and lock electrical circuits and equipment in accordance with established safety practices.
4. Is trained in the proper use and care of personal protective equipment (PPE) in accordance with established safety practices.
5. Is trained in the commissioning, operation, and maintenance of equipment in hazardous locations — in cases where the device is installed in a potentially explosive (hazardous) location.

SERIES 7000/8000 3-PIECE FULL PORT BALL VALVE

Installation, Operation, and Maintenance Manual



4.0 PARTS IDENTIFICATION

4.1 Parts Callout - NPS ¼ to 2½ | DN 8 to 65

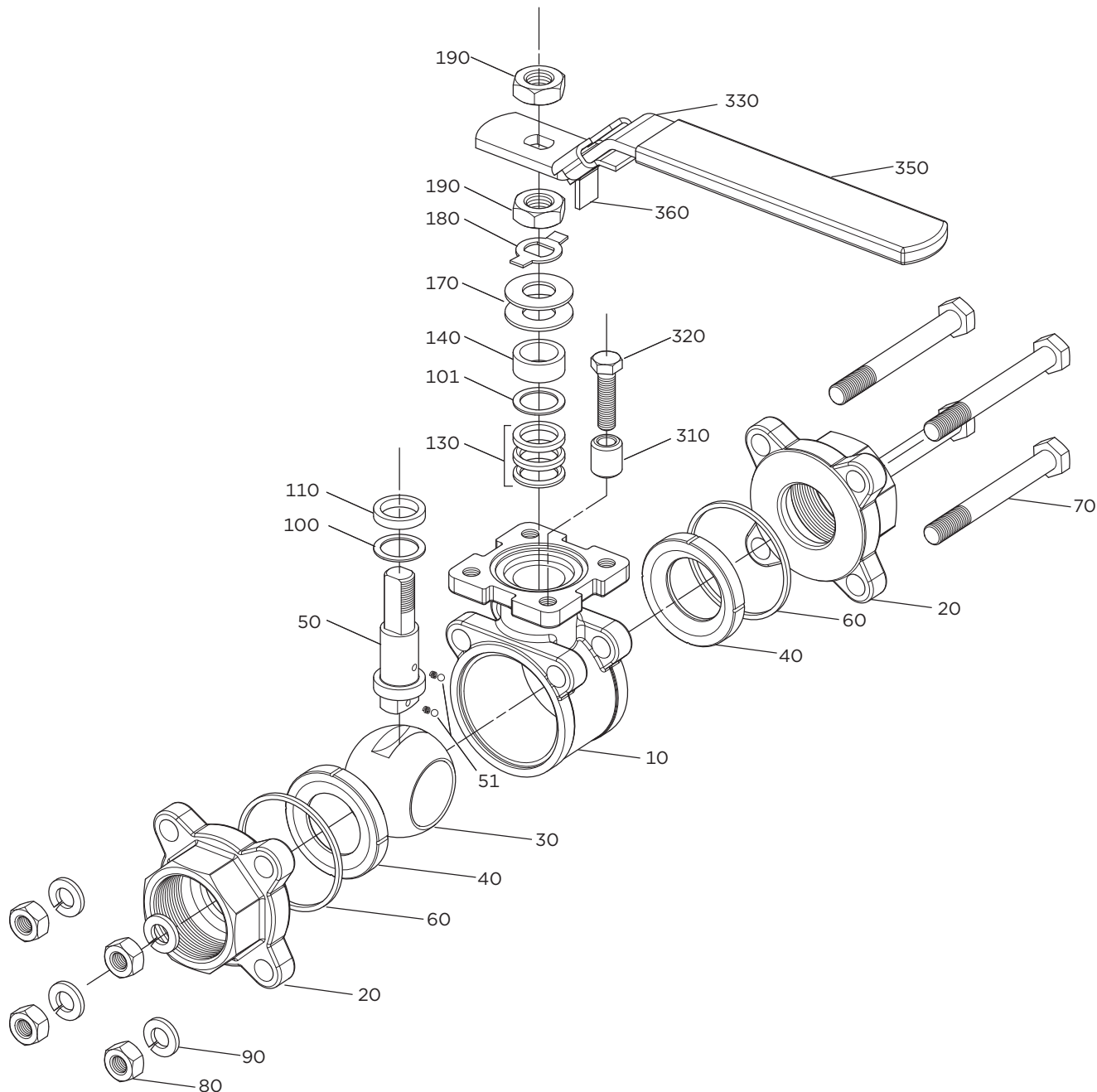

SERIES 7000/8000 3-PIECE FULL PORT BALL VALVE

Installation, Operation, and Maintenance Manual



4.2 Parts List - NPS ¼ to 2½ | DN 8 to 65

ITEM	DESCRIPTION	RECOMMENDED SPARE PARTS ¹
10	Body	
20	End Cap	
30	Ball	
40	Seat	■
50	Stem	
51	Anti-Static Device	
60	Body Seal	■
70	Body Bolt/Stud	
80	Body Nut	
90	Spring Washer	
100	Thrust Washer Protector	■
101	Packing Protector	■
110	Thrust Washer	■
130	Stem Packing	■
140	Packing Gland	
170	Belleville Washers	
180	Tab Lock Washer	
190	Lock Nut	
310	Travel Stop Set Sleeve	
320	Travel Stop Bolt	
330	Handle	
350	Handle Sleeve	
360	Locking Device	

NOTE:

1. Items contained in repair kit

4.3 Parts Callout - NPS 3 and 4 | DN 80 and 100

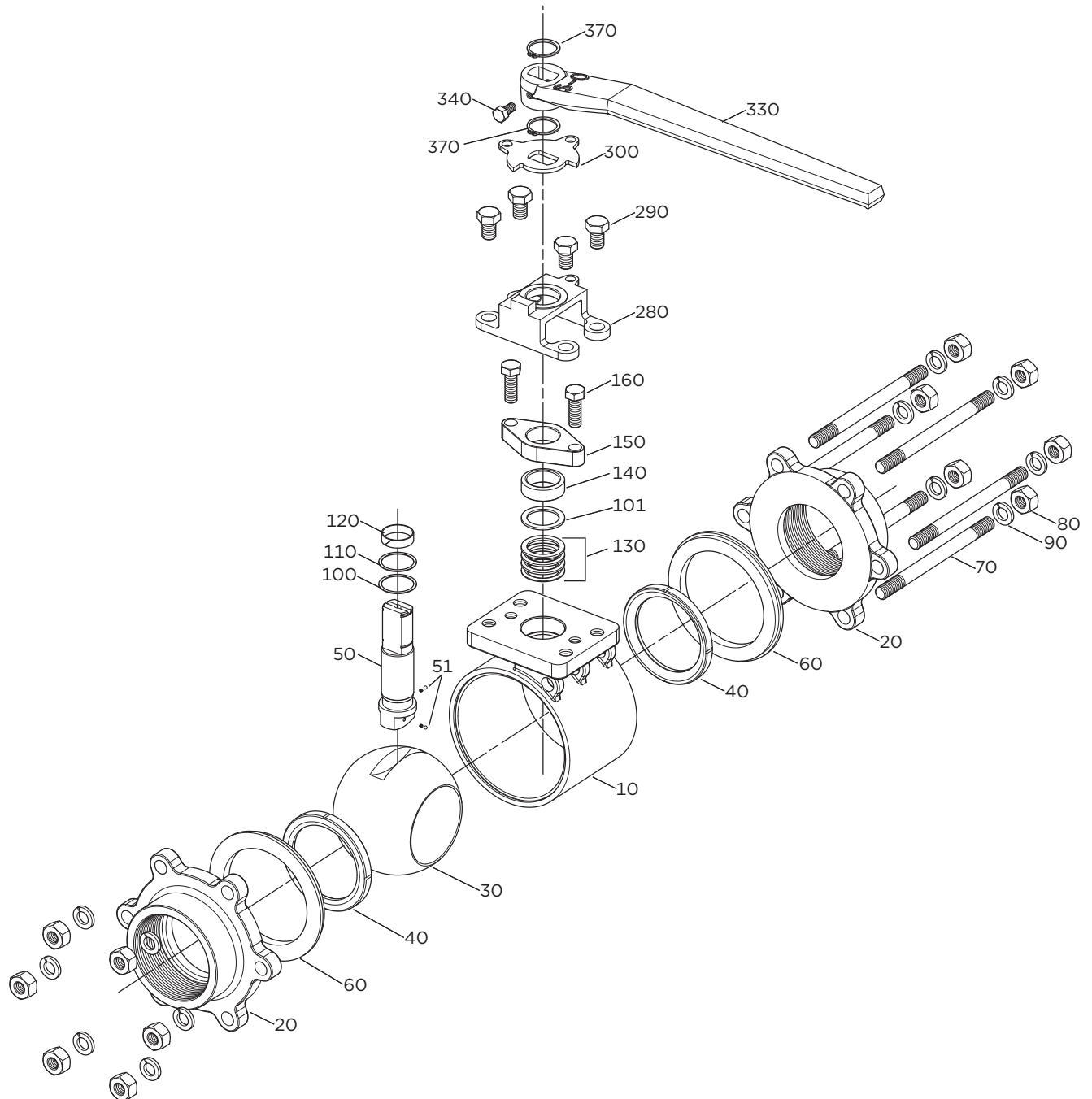

SERIES 7000/8000 3-PIECE FULL PORT BALL VALVE

Installation, Operation, and Maintenance Manual



4.4 Parts List - NPS 3 and 4 | DN 80 and 100

ITEM	NAME	RECOMMENDED SPARE PARTS ¹
10	Body	
20	End Cap	
30	Ball	
40	Seat	■
50	Stem	
51	Anti-Static Device	
60	Body Seal	■
70	Body Bolt/Stud	
80	Body Nut	
90	Spring Washer	
100	Thrust Washer Protector	■
101	Packing Protector	■
110	Thrust Washer	■
120	Stem Bearing	■
130	Stem Packing	■
140	Packing Gland	
150	Packing Follower	
160	Gland Bolt	
280	Travel Stop Housing	
290	Housing Bolt	
300	Travel Stop Plate	
330	Handle	
340	Handle Bolt	
370	Snap Ring	

NOTE:

1. Items contained in repair kit

SERIES 7000/8000 3-PIECE FULL PORT BALL VALVE

Installation, Operation, and Maintenance Manual



4.5 Parts Callout - NPS 6 and 8 | DN 150 and 200

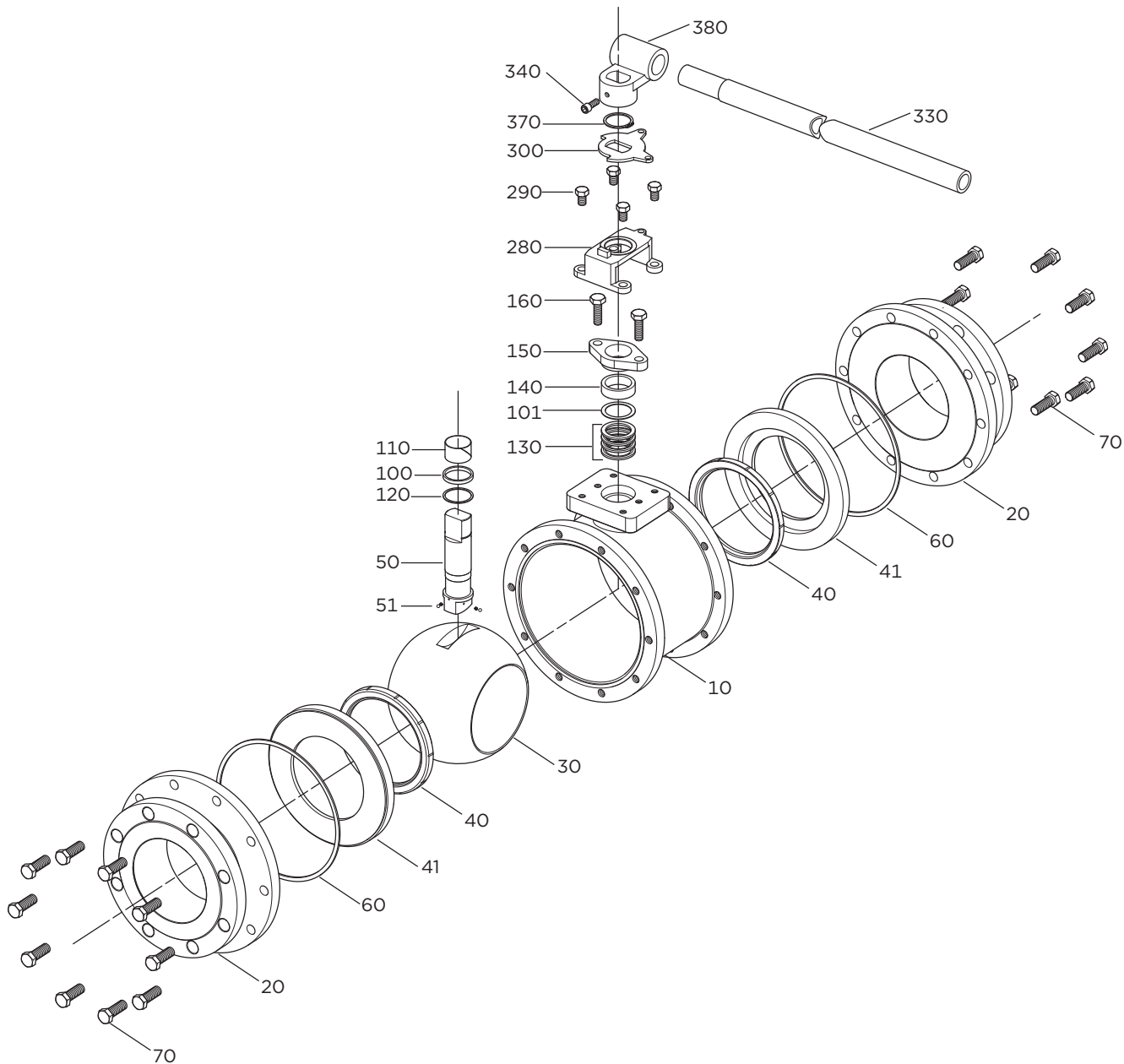

SERIES 7000/8000 3-PIECE FULL PORT BALL VALVE

Installation, Operation, and Maintenance Manual



4.6 Parts List - NPS 6 and 8 | DN 150 and 200

ITEM	NAME	RECOMMENDED SPARE PARTS ¹
10	Body	
20	End Cap	
30	Ball	
40	Seat	■
41	Seat Support	
50	Stem	
51	Anti-Static Device	
60	Body Seal	■
70	Body Bolts	
100	Thrust Washer Protector	■
101	Packing Protector	■
110	Thrust Washer	■
120	Stem Bearing	■
130	Stem Packing	■
140	Packing Gland	
150	Packing Follower	
160	Gland Bolts	
280	Travel Stop Housing	
290	Housing Bolts	
300	Travel Stop Plate	
330	Handle	
340	Handle Bolt	
370	Snap Ring	
380	Handle Junction	

NOTE:

1. Items contained in repair kit

4.7 Parts Callout - NPS 10 and 12 | DN 250 and 300

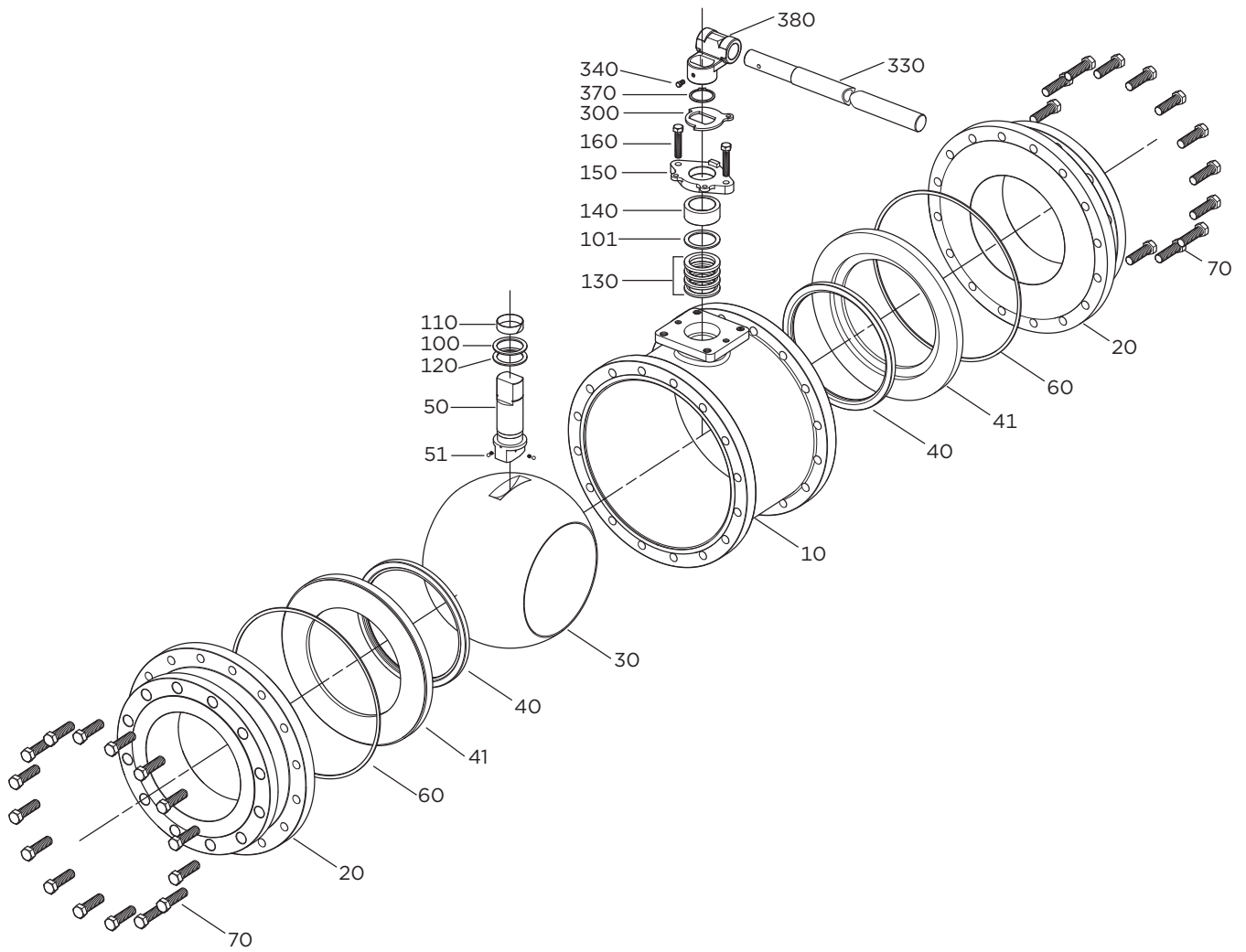

4.8 Parts List - NPS 10 and 12 | DN 250 and 300

ITEM	NAME	RECOMMENDED SPARE PARTS ¹
10	Body	
20	End Cap	
30	Ball	
40	Seat	■
41	Seat Support	
50	Stem	
51	Anti-Static Device	
60	Body Seal	■
70	Body Bolt	
100	Thrust Washer Protector	■
101	Packing Protector	■
110	Thrust Washer	■
120	Stem Bearing	■
130	Stem Packing	■
140	Packing Gland	
150	Packing Follower	
160	Gland Bolt	
300	Travel Stop Plate	
330	Handle	
340	Handle Bolt	
370	Snap Ring	
380	Handle Junction	

NOTE:

1. Items contained in repair kit.

4.9 Spare Parts

1. Use only Bray original spare parts.
2. Recommended spare parts are identified in the Parts Identification drawing and list for each product model.
3. Bray cannot accept responsibility for any damages that occur from using spare parts or fastening materials from other manufacturers. If Bray products (especially soft good materials) have been stored for long periods of time, check them for corrosion or deterioration before putting them into use.



WARNING

Before products are returned to Bray for repair or service, Bray must be provided with a certificate that confirms that the product has been decontaminated and is clean.

5.0 VALVE IDENTIFICATION

Identification Tag

All valves, actuators, or control products are provided with a permanently affixed identification tag meeting the requirements of applicable standards and certifications for the product.

As each product is unique, data may vary.

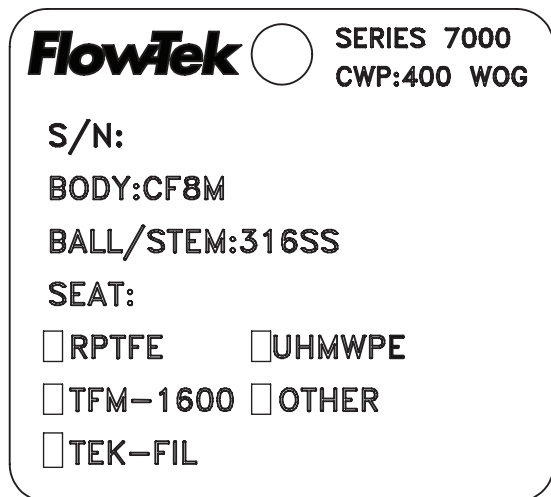

Series	7000 or 8000
CWP	Maximum Pressure at Ambient Temperature
S/N	Valve Serial Number
Body	Body Material
Ball/Stem	Ball Material/Stem Material
Seat	Seat Material

6.0 HANDLING REQUIREMENTS



WARNING

A potential hazard exists with handling valves. Failure to handle valves properly may cause a valve to shift, slip or fall causing serious injury or death and/or equipment damage.

6.1 Packed Valves

Crates: Lifting and handling of the packed valves in crates will be carried out by a forklift truck, by means of the appropriate fork hitches.

Cases: The lifting of packed valves in cases will be carried out in the lifting points and in the center of gravity position which has been marked. The transportation of all packed material must be carried out safely and following the local safety regulations.

Moving crated, packed, or palleted products must be done in a safe manner, using appropriate lifting equipment (i.e., forklift, hand truck, pallet jack, etc.)



NOTICE

When lifting the valve from shipping container, use straps through valve body. Take care to position lifting straps to avoid damage to the tubing and mounted accessories.

6.2 Unpacked Valves

Lifting and handling of valves should be carried out by using appropriate means and observing the carrying limits. Handling must be carried out on pallets, protecting all machined surfaces to avoid any damage.

With large bore valves, rigging the load must be carried out by using the appropriate tools to prevent the valve from falling or moving during the lifting and handling.



CAUTION

Product is shipped in protected position and must be transported in such a way as to avoid damage during movement.

For handling and/or lifting, the lifting equipment (fasteners, hooks, etc.) must be sized and selected while considering the product weight indicated in our packing list and/or delivery note.

Lifting and handling must be performed only by qualified personnel.

Fasteners must be protected by plastic covers in sharp corner areas.

Caution must be taken during handling to avoid this equipment passing over workers, or over any other place where a possible fall could cause injury or damage. In all cases, local safety regulations must be respected.



CAUTION

The end connection necks are suitable places to attach lifting slings/straps. Never use hand wheels or other protruding parts of the gearbox or actuator not designated for this purpose.



NOTICE

During handling, protect the end connection faces and fittings against damage from the lifting devices. Failure to cover faces and fittings could cause damage to the valve.

While unpacking the valve, check the packing list against the materials received. Lists describing the valve and accessories are included in each shipping container and General Assembly drawing as applicable.



WARNING

Never lift the valve or valve package by the actuator, positioner, limit switch or their piping. When lifting a valve, be aware that the center of gravity may be above the lifting point. Therefore, support must be given to prevent the valve from rotating. Failure to do so can cause serious injury to personnel and damage to the valve and nearby equipment.

Contact your shipper immediately if there is shipping damage. Should any problem arise, call your Bray representative.



WARNING

A potential hazard exists with handling valves. Failure to handle valves properly may cause a valve to shift, slip or fall causing serious injury or death and/or equipment damage.

6.3 Moving Valves

Moving crated, packed, or palleted products must be done in a safe manner, using appropriate lifting equipment (i.e., forklift, hand truck, pallet jack, etc.)

Lifting of products should be done using lifting points, and in the center of gravity position as marked, in observance of existing carrying limits.



CAUTION

Product is shipped in protected position and must be transported in such a way as to avoid damage during movement.

For handling and/or lifting, the lifting equipment (fasteners, hooks, etc.) must be sized and selected while considering the product weight indicated in our packing list and/or delivery note.

Lifting and handling must be performed only by qualified personnel.

Fasteners must be protected by plastic covers in sharp corner areas.

SERIES 7000/8000 3-PIECE FULL PORT BALL VALVE

Installation, Operation, and Maintenance Manual



Caution must be taken during handling to avoid this equipment passing over workers, or over any other place where a possible fall could cause injury or damage. In all cases, local safety regulations must be respected.

7.0 TRANSPORT AND STORAGE



NOTICE

Failure to follow these procedures could affect product warranty.

The packaging is designed to protect the products only during shipping. If the product is not installed immediately after delivery, then it must be stored according to these requirements.

These are general guidelines for valve storage. Storage guidelines for accessories fitted on valves shall be as per respective Installation, Operation and Maintenance manual. Please consult the factory for information regarding specific requirements.

7.1 Transport

Upon arrival at the site, valves general condition should be inspected right away for any potential shipping damage. Any damage should be reported to Bray.

7.2 Short-Term Storage

Short-term storage is defined as storage of products and equipment to be used in the construction of a project for periods of one to three months. Short-term storage must be carried out in a controlled manner as follows:

1. Valves must be stored in a closed, clean, and dry environment.
2. Ball valves should be stored in the fully open position to protect the ball and seats.
3. Ball valves should remain in the original shipping container and be placed on pallets of wood or other suitable materials. End protectors should remain on the valve ends to prevent the entrance of dirt and removed only at time of installation.

7.3 Long-Term Storage

Long-term storage is defined as storage of products and/or equipment for periods longer than 3 months. Long-term storage must be carried out in a controlled manner as follows:

1. Valves must be stored in a closed, clean, and dry environment.
2. Ball valves should be stored in the fully open position to protect the ball and seats.
3. Ball valves should remain in the original shipping container and be placed on pallets of wood or other suitable materials. End protectors should remain on the valve ends to prevent the entrance of dirt and removed only at time of installation.
4. A visual inspection (with results recorded) shall be performed every three months to ensure the above conditions are maintained.

Inspection, as a minimum, shall include reviewing the following:

- > Packaging
- > Flange covers
- > Dryness
- > Cleanliness

These are general guidelines for valve storage. Please consult the factory for information regarding specific requirements.



CAUTION

Do not stack the products on top of each other.

7.4 General Storage Requirements

Manually actuated valves may be stored in the vertical or horizontal position. For air or hydraulically actuated valves, the preferred orientation is with the valve stem in the vertical position. Access ports should be secured to prevent unauthorized entry and prevent contamination.

The preferred storage location is a closed, clean, and dry environment. Do not expose the product to temperature extremes.



NOTICE

The preferred temperature range is 40°F (4°C) to 85°F (29°C). For long-term storage in temperatures lower or higher than the preferred range, please consult the factory for information regarding specific requirements.

End protectors shall remain on the valve ends to prevent the entrance of dirt, debris, or insects/wildlife.

Product shall remain in the original shipping container with the original packaging materials.

Valves and equipment containing elastomers, including O-rings, must be stored in a climate-controlled warehouse according to SAE-ARP5316D requiring:

1. The ambient relative humidity to be less than 75%.
2. No exposure from direct ultraviolet or sunlight.
3. Protection from ozone generating equipment or combustible gases and vapors.
4. Storage at temperatures below 100°F (38°C), away from direct sources of heat.
5. No exposure to ionizing radiation.

8.0 INSTALLATION

8.1 Considerations



NOTICE

Certain valve constructions are uni-directional. A flow arrow will indicate the flow direction. Care should be taken when installing the valve to ensure these special constructions.

The valve may be fitted in any position on the pipeline.

Before installing the valves, the pipes must be flushed clean of dirt, burrs, and welding residues, or the seats and ball surface will be damaged. Check pipe end connections (threads, flanges, weld end connections, etc) to ensure they are not damaged.

If for any reason the valve is installed prior to flushing of the piping system, the valve must remain in the full open position until the piping system has been fully flushed clean of debris.

Ensure the adjoining pipe on each end of the valve is aligned to prevent external piping loads. Piping misalignment may cause excessive external loads on the valve resulting in body joint leaks.

For hydrostatic testing of the piping system, the valves must be placed in the full or half open position prior to pressurizing the system.



NOTICE

Hydrostatic system testing with the valve in the closed position may result in damage to the valve seats, affecting their ability to create a proper seal.

Failure to implement the installation and testing instructions as outlined, resulting in a valve failure, will void the warranty coverage of the product.

When installing valves verify the orientation of handle, actuator and/or actuation accessories are not interfering with existing piping, equipment, or structure.

8.2 Actuator Installation

1. It is recommended to allow sufficient space for removal when actuator package is installed.
2. It is recommended to install the actuator package with the valve stem in the upright position. If stem is in other than vertical position, actuator package weight support is recommended to avoid any possibility of side load during operation.
3. It is recommended to avoid installing the actuator package where the actuator or accessories are in contact with the pipeline or pipeline structure.



WARNING

Keep hands and other body parts clear of the valve flow port and other rotating machinery.

4. Prior to putting the valve into service, cycle the valve/ actuator to ensure valve, actuator and accessories operate properly.

8.3 Actuator Mounting



NOTICE

Remove components related to handle prior to installing actuator mounting set. **Specifically on the 10" & 12" (DN 250 & 300)** valve, ensure the travel stop plate and lower snap ring are removed.

1. Inspect the valve actuator mounting surface, stem, mounting hardware, bracket, coupling/adaptor and actuator package for damage, wear or any other irregularity which could affect the operation and performance of the valve or actuator package.
2. Follow specific actuator installation, operating and maintenance instructions.
3. Select a desired orientation for the actuator mounting relative to the ball position.
4. Valve stem shall be in the upright position.
5. Ensure valve is properly supported when mounting the actuator.
6. Valve closure position per Section 9.
 - a. If the actuator is a spring return fail to close or double acting style actuator, the valve closure shall be set to closed position.
 - b. If the actuator is a spring return fail to open style actuator, the valve closure shall be set to open position.
7. Attach the mounting bracket to the valve with provided hardware hand tight. A lifting device may be required based on the size and weight of the bracket.
8. Install the coupling/adaptor on the valve stem. A lifting device may be required based on the size and weight of the coupling/adaptor.
9. Proper valve and actuator performance requires alignment between the valve stem and actuator drive. Misalignment can cause premature wear of the valve and actuator components.
10. Ensure actuator drive orientation is in the proper position.
11. Lift the actuator package from its storage location and lower the actuator so the actuator drive is in a direct line with the valve stem. Support actuator package once actuator is on the mounting bracket. Be careful not to force the valve stem into the valve as the actuator drive and stem are in contact.



NOTICE

It may be necessary to loosen the mechanical stop to allow the mounting holes to align properly. Refer to actuator installation instructions.

12. Tighten the actuator provided mounting hardware hand tight. Maintain the actuator package support.
13. Cycle actuator 2 to 3 times to allow the assembly to center the valve stem, coupling/adaptor, and actuator drive.
14. Tighten the mounting hardware at the valve and actuator.
15. The actuator travel stops shall be adjusted to ensure proper valve closure position, open and closed. The actuator stops shall be set every time the actuator is removed from the valve.



CAUTION

Valves can leak through bore if proper care is not exercised during the setting of Open and/or Closed stops.

8.4 Installation of Threaded End Valves

Valve can be screwed on without the use of union or with the end caps removed from the body.

The use of a thread sealant is recommended.

Apply wrench only on the hex/octagon valve end being tightened. Do not tighten by applying torque to the opposite end cap or other valve component.



NOTICE

Tightening by using the valve body, handle or the opposite end cap can seriously damage the valve. Use a wrench on both the second end cap and pipe to avoid applying torque to the body through the bolting.

In some applications, screwed valves may be back-welded. Disassemble as per instructions for weld end valves.

Confirm that the end cap bolt holes are aligned with the body screw holes on both ends and that the end caps are parallel and correctly spaced to fit the valve body before reassembly or back welding.

Make up both of the threaded connections normally and then remove the body assembly as described in Section 8.6 for weld end connections before back welding the threaded connection.



NOTICE

Do not use the body screws to pull the pipe ends together or into alignment.

8.5 Installation of Extended Weld-End Valve



NOTICE

Ensure that appropriate weld procedures are implemented that are compatible with the materials used.

Valves with 3 inch or longer extended weld ends do not require disassembly for installation welding. Valves with non-extended ends should follow the requirements of Section 8.6.

Clean the pipeline, connecting valve weld end, and the weld area on the pipe.

When welding the valve into line, verify that the ball is in the fully open position (the valve is in the open position when the handle is parallel to the axis of the valve and pipe) prior to welding to protect the ball sealing surface from possible damage. Ensure that the piping and valve end connections are properly aligned to avoid line bind.

Apply a welding ground strap adjacent to the valve end being welded to prevent current flow through the valve.

Follow the appropriate welding procedures per the applicable industry standards that are compatible with the valve and piping materials being joined. While welding, monitor the valve body temperature near the seat pockets using a temperature indicator stick, ensuring that the temperature does not exceed 93°C (200°F).

After welding, follow the appropriate post weld heat treatment (PWHT) procedures per the applicable standards. PWHT shall be performed localized. To avoid excessive body temperatures, perform PWHT to one end of the valve and then normalize to ambient temperature before proceeding to the second end of the valve.

After installation, with the valve still in the open position, flush the piping system and valve clean again to remove any dirt, burrs, and welding residue that may have accumulated during valve installation.

After installation and flushing of the piping system, verify smooth operation by cycling the valve several times

8.6 Installation of Weld-end (Tank Bottom and Non-Extended) Valves



NOTICE

Ensure that appropriate weld procedures are implemented that are compatible with the materials used.

These instructions apply to Tank Bottom Series TK7000/TK8000 valves and any other valve with short welded end connections.

1. Ensure that the piping and valve end connections are properly aligned to avoid line bind.

2. Tack weld the valve to the pipe at four points on both end caps.
3. With the valve in open position, (the valve is in the open position when the handle is parallel to the axis of the valve and pipe), loosen all body bolts, remove the body from between the end caps.
4. Turn the handle in the half open position to assist in the removal of the seats and inner body gaskets.
5. Turn handle in closed position and remove ball.
6. Place all removed parts in a clean and secure place.
7. Replace the body and all body bolts and tighten them hand tight. This operation is very important, so that the body and end caps remain perfectly parallel, thus preventing any leakage at the body joint after welding.
8. Apply a welding ground strap adjacent to the valve end being welded to prevent current flow through the valve.
9. Follow the appropriate welding procedures per the applicable industry standards, that are compatible with the valve and piping materials being joined. While welding, monitor the valve body temperature near the seat pockets using a temperature indicator stick, Ensuring that the temperature does not exceed 93°C (200°F).
10. After welding, follow the appropriate post weld heat treatment (PWHT) procedures per the applicable standards. PWHT shall be performed localized. To avoid excessive body temperatures, perform PWHT to one end of the valve and then normalize to ambient temperature before proceeding to the second end of the valve.
11. When valve components and piping have cooled to ambient temperature, remove body bolting and body. Turn valve stem to closed position an insert the ball.
12. Turn valve stem to open position and insert seats and new body seals.



NOTICE

Use spare body gaskets for reassembly as the original body gasket will have been compressed during the original assembly and tightening of the body bolts

13. Place body between the two end connections; then replace all bolts. Lubricate threads and the bolt and nut faces in contact with the end caps with anti-seize thread lubricant compatible with the media.



CAUTION

Do not use body bolting to align piping. This can damage the valve and cause body seal leakage.



NOTICE

Body bolts/body nuts must be tightened in a cross or star pattern to prevent uneven loading of the body seal.

14. Tighten the body bolts in a cross pattern per **Figure 1** based on number of fasteners per body joint. Fastener torque should be applied at 30%, 60% and 100% and once more at 100% increments per **Table 1** values to ensure proper gasket seating.
15. After installation, with the valve still in the open position, flush the piping system and valve clean again to remove any dirt, burrs, and welding residue that may have accumulated during valve installation.
16. After installation and flushing of the piping system, verify smooth operation by cycling the valve several times.

8.7 After Installation

After valve has been installed in the pipeline and prior to any system testing or start up, tighten the gland locking nut or gland bolts per **Table 2**.

Table 1: End Cap Fastener Tightening Torques

Valve Size		Torque	
Inch	mm	lbs-in	N m
¼	8	70	7.9
⅜	10	70	7.9
½	15	70	7.9
¾	20	80	9
1	25	100	11.3
1¼	32	160	18.1
1½	40	230	26
2	50	350	39.5
2½	65	820	92.6
3	80	70	7.9
4	100	90	10.2
6	150	Contact Bray	
8	200	Contact Bray	
10	250	Contact Bray	
12	300	Contact Bray	

Table 2: Stem Packing Fastener Tightening Torques

Valve Size		Torque	
Inch	mm	lbs-in	N m
¼	8	50	5.6
⅜	10	50	5.6
½	15	50	5.6
¾	20	50	5.6
1	25	90	10.2
1¼	32	90	10.2
1½	40	170	19.2
2	50	170	19.2
2½	65	240	27.1
3	80	180	20.3
4	100	180	20.3
6	150	Contact Bray	
8	200	Contact Bray	
10	250	Contact Bray	
12	300	Contact Bray	

Figure 1 - Body Joint Bolting Guide

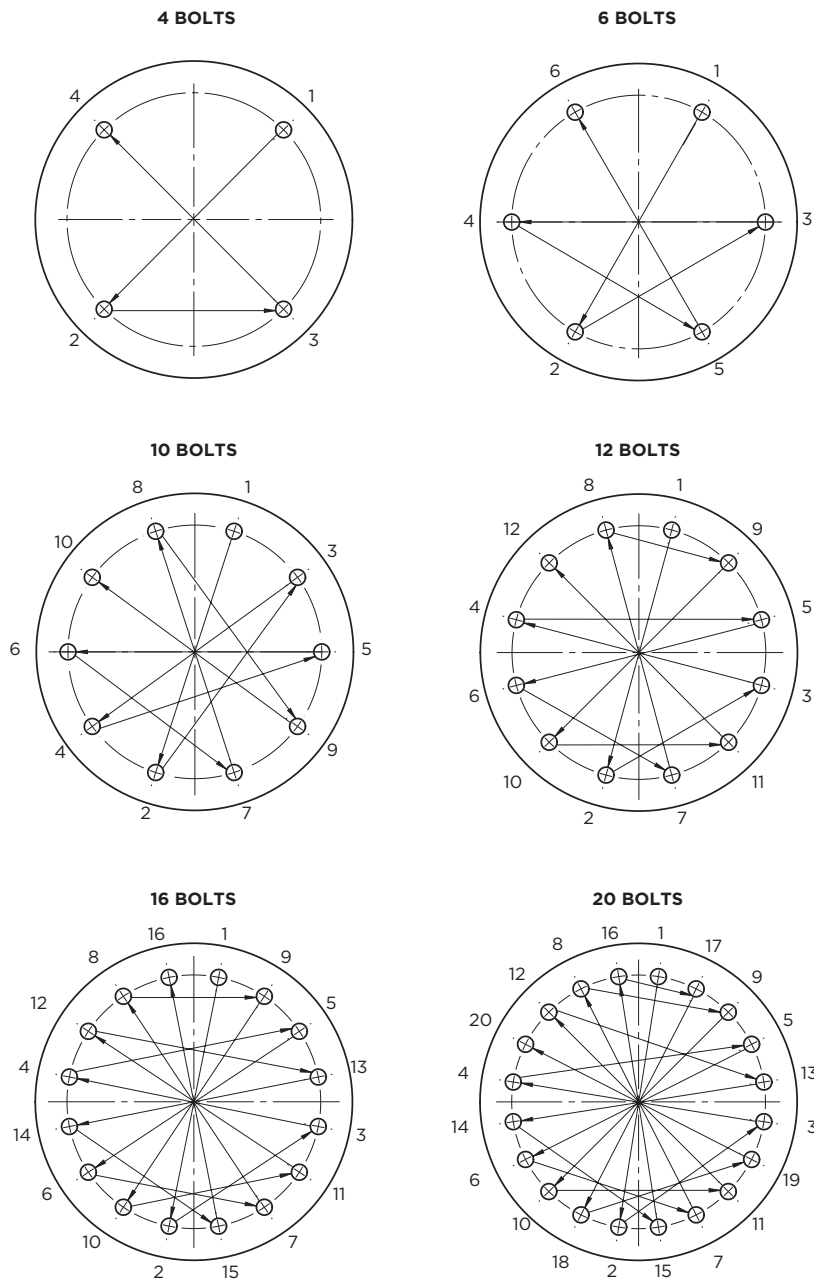

Table 3: Series 7000/8000 Body Bolting

Valve Size		No of Bolts
NPS	DN	
¼	8	4
⅜	10	4
½	15	4
¾	20	4
1	25	4
1¼	32	4
1½	40	4
2	50	4
2½	65	4
3	80	6
4	100	6
6	150	10
8	200	12
10	250	16
12	300	20

9.0 OPERATION

Operation of the valve is done by turning the handle a quarter-turn (90 degree turn). Clockwise to close, counterclockwise to open.

Valve In Open Position - The handle is parallel with the pipeline.

Valve In Closed Position - The handle is perpendicular to the pipeline.



CAUTION

Valves with actuators should be checked for actuator/valve alignment. Misalignment will result in high operational torque, and cause damage to valve stem and seals.

OPEN POSITION

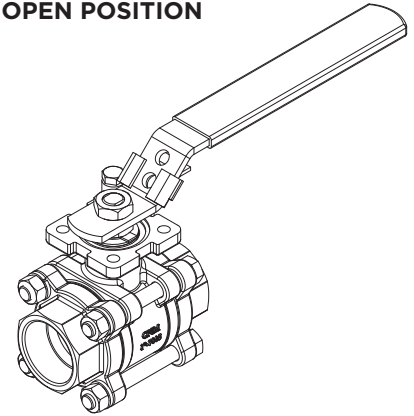

CLOSED POSITION

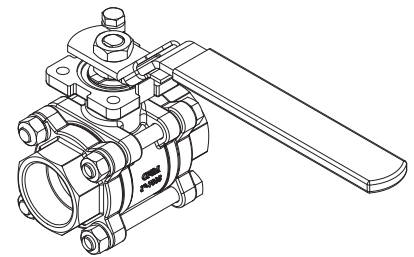

10.0 MAINTENANCE AND REPAIR



NOTICE

The valve may be assembled and operated dry where no lubricants are allowed in the system; however, a light lubrication of mating parts will aid in assembly and reduce initial operating torque. Lubricant used must be compatible with the intended line fluid.

10.1 Stem Seal Adjustment



WARNING

DO NOT attempt to remove packing components or any other valve parts while line is under pressure.

Stem packing may be corrected without disassembly of the valve by tightening the lower lock nut or gland bolts until such leakage stops. If the leakage continues or valve operating torque becomes excessive, the seals are worn and replacement will be necessary.

For ¼" - 2½" (DN 8 - 65), if slight leakage is noted at the stem, straighten lock washer tab, tighten lower lock nut to flatten Belleville washers, back lower lock nut off 1/4 turn, secure tab lock washer by bending the flat against the nut.

For sizes 3" (DN80) and larger, if slight leakage is noted at stem, simply tighten gland bolts evenly in ¼ turn increments until the leak stops. Do not over tighten. Be careful to not over tighten the packing as this can result in excess operating torque and accelerated wear of the packing.

See **Table 2** for recommended stem gland nut and gland bolt torque for a new valve assembly. When making packing adjustments while the valve is in service, torque values may vary due to cycle frequency, temperature, and other operating conditions.

10.2 Actuator Removal

1. Follow specific actuator installation, operating and maintenance instructions.
2. Ensure valve is properly supported when removing the actuator.
3. If the valve is in the pipeline, the process shall be stopped.
4. Disconnect all energy sources (electrical, pneumatic, or hydraulic) prior to removing the actuator.
5. Properly support actuator assembly.
6. Remove and store mounting hardware.
7. Lift the actuator package in a direct line with the valve stem until the actuator, coupling/adaptor is clear of the valve.
8. The actuator package shall be placed in a place which will avoid damage and personal injury.

9. Remove and store mounting bracket and coupling/adapter. A lifting device may be required based on the size and weight of the bracket and coupling/adapter.

10.3 Valve Removal from System and Cleaning Procedure



CAUTION

Line must be depressurized before disassembly. Valve should be cycled to assure there is no pressure trapped in valve cavity. Ball valves can trap pressurized media when closed.

Flush line with valve 1/2 open to remove media. If the valve has been used to control hazardous media, it must be decontaminated before disassembly.



WARNING

DO NOT attempt to remove packing components or any other valve parts while line is under pressure!



CAUTION

Properly support the valve before removing or loosening any body bolts. The larger sizes are heavy and may cause injury if allowed to swing or fall freely.



WARNING

Remove actuation media and power connections and confirm that there is no stored energy in the actuation such as compressed springs or trapped air before beginning. Stored energy devices can cause serious injury if the energy is released without warning.



NOTICE

Certain valve constructions are uni-directional. A flow arrow will indicate the flow direction. Care should be taken when rebuilding the valve to ensure these special constructions are considered.

It is recommended that the following steps be taken for safe removal and assembly.

10.4 Valve In-line Service



NOTICE

Disassembly for servicing seats and stem seals may be performed without removing the end flanges from the pipeline. This feature allows the removal of the valve from service without disturbing piping connections.

The unique body design offers many advantages, including ease of in-line servicing. These time saving features are beneficial for process industries, automated valves and welded piping systems by reducing costly downtime.

In-line service is recommended for valves sizes up to and including NPS 4 (DN 100). It is not recommended to perform in-line service for valves NPS 6 (DN 150) and larger by swinging the center section out due to the size and weight of the body center section.



WARNING

For actuated valves, properly support valve center section, actuator, and actuator accessory weight.



NOTICE

If valve is actuated and complete repair including stem packing is required, out-of-line servicing shall be followed.

During maintenance, the actuator, mounting and accessories remain on the valve body. No actuator adjustment or reattachment is necessary.

1. Support valve and actuator assembly before removing from pipeline
2. Open valve.
3. Loosen one of the upper body bolts and remove the remaining bolts. The center body will swing out leaving the end caps in place on the pipe ends. Secure body subassembly. The heavy duty bolts, throughout the entire size range, provide positive alignment of body to end connection during swing-out, in-line servicing.
4. Follow component disassembly, visual inspection and valve assembly procedures in following sections.

Figure 2 - In-line Valve Service

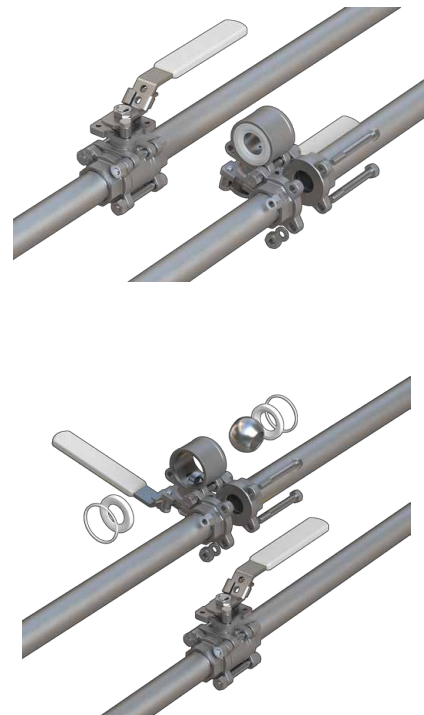

10.5 Valve Disassembly



NOTICE

Certain valve constructions are unidirectional. A flow arrow will indicate the flow direction. Care should be taken when rebuilding the valve to ensure these special constructions are considered.



NOTICE

These instructions shall be followed for in-line or out-of-line servicing.



NOTICE

When removing soft goods care should be taken to not damage sealing surfaces. Damage to sealing surfaces will affect the performance of the valve.

1. Support valve and actuator assembly before removing from pipeline.
2. Open valve.
3. Remove valve from pipeline either by unscrewing threaded portion of pipe while supporting valve end with a wrench, loosen and remove pipeline flange bolting or remove body center section. To remove body center section, loosen body bolts on both sides using the proper wrench.
4. Lift valve from line for servicing. Proper lifting and handling techniques shall be followed to remove the valve and actuator from pipeline. They should be adequately supported before removal from the line is begun.



NOTICE

Care should be taken to avoid scratching or damaging serrated flange face. The valve should be adequately supported before beginning.

5. For valves with actuation and accessories mounted, remove valve actuation, accessories and valve to actuator mounting parts. Store actuation, accessories and valve to actuator mounting parts per their installation, operating and maintenance instructions.
6. Once valve has been removed from the pipeline, hold the body in a vise firmly enough to prevent movement but do not crush or damage the body.

7. Perform the following:
 - NPS $\frac{1}{4}$ - $2\frac{1}{2}$ (DN 8 - 65) sizes; Remove the upper lock nut and handle. Straighten the tab on the tab lock washer and remove the lower lock nut. Remove the tab lock washer, Belleville washers, and packing gland.
 - NPS 3 - 4 (DN 80 - 100) sizes; Remove the upper snap ring. Loosen the handle bolt and remove the handle. Remove the lower snap ring, travel stop plate, housing bolts and travel stop housing. Remove the gland bolts, packing gland follower, and packing gland.
 - NPS 6 - 12 (DN 150 - 300) sizes; Loosen the handle bolts and remove the handle and handle junction. Remove the snap ring, travel stop plate, housing bolts and travel stop housing. Remove the gland bolts, packing gland follower, and packing gland.
8. If not previously done when removing valve from pipeline remove body bolts, using proper wrench size. Lift off end cap.
9. Repeat the removal procedure for the other end. Take out other seat.
10. Carefully remove body seals watching to not damage sealing surfaces. Damage to sealing surfaces will affect the performance of the valve.
11. To remove the ball, rotate the stem so ball is in full closed position. Lift the ball from body, using a strap and lift device if necessary.



NOTICE

Extreme caution should be taken to avoid damage to the ball.

12. The stem must be removed from inside the body - a tap with a rubber mallet, block of wood or hard plastic rod on the top of the stem should loosen it. The thrust washer should come out with the stem. Then remove the stem packing.
13. Discard all soft seals.

10.6 Visual Inspection

Clean and inspect metal parts. It is not necessary to replace the ball and stem unless the sealing surfaces have been damaged by scratches, abrasion, or corrosion.

Verify threads and threaded holes are clean are free from thread locker, paint, media, and foreign material.

Check all sealing areas on metal parts for damage.

Replacement of all soft parts is strongly recommend whenever the valve is disassembled for reconditioning. This is the surest protection against subsequent leakage after valve assembly. The replacement parts can be ordered in kit form.

10.7 Valve Assembly Procedures NPS ¼ - 2 | DN 8 - 50



NOTICE

Certain valve constructions are uni-directional. A flow arrow will indicate the flow direction. Care should be taken when rebuilding the valve to ensure these special constructions are considered.

1. Hold the body in a vise firmly enough to prevent movement but do not crush or damage the body.
2. Place the thrust washer protector and thrust washer on the stem and slide the stem into the stem hole in the valve body. Be careful not to damage the stem or body.
3. Holding stem up inside valve body, install the stem packing onto the stem until it is rested against the bottom of the packing bore. See **Figure 3** for proper orientation.
4. Install the packing protector and then the packing gland onto the stem, and top of the stem packing.
5. Install the Belleville washer together in series (bottom Belleville washer curve facing up, the top Belleville washer curve facing down see **Figure 4**, and then place them onto the stem, on top of the packing gland.
6. Install the tab lock washer over the stem and on top of the Belleville washers.
7. Thread the lock nut and tighten the nut to the torques in **Table 2**.



NOTICE

The use of a bore alignment tool, about 0.04 inches (1.0mm) less than the internal diameter of the end cap and ball, inserted through the end cap and ball will prevent the ball from turning as the lock nut is tightened on the stem.

Material for the bore alignment tool should be made from a material softer than 300 Series SS so that it will not inadvertently scratch the valve end cap or ball. Suggested materials: aluminum T6061, acetal or other suitable hard polymer/plastic material.

8. Secure the tab lock washer with one ear bending up against the flat of the nut.



NOTICE

If valve will be automated, Steps 9 and 10 are not required

9. If valve is equipped with a handle, place the handle onto the stem, on top of the lock nut.
10. Thread the lock nut on the stem and tighten the nut to secure the handle.

Figure 3 - Stem Seal Packing Orientation



V-ring Packing

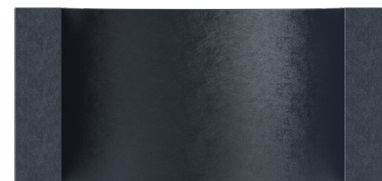

Graphite Packing



Combo Packing

Figure 4: Belleville Washer Orientation



11. Rotate the stem to the closed position and install the ball inside the valve body. The stem flats will fit into the slot on top of the ball. Lifting aid may be required to install the ball. Be careful not to damage sealing surfaces of ball or body.
 - > For V-Control valves, insert V-ball with V opening being on right side of the stem, so when valve fully open, V will face downstream seat following flow arrow marked on the body.
12. Turn the stem so that the ball is in the open position (the ball will not fall out of the valve).
13. Install the seats inside the body and body seals inside an end cap, make sure the spherical curvature side of the seat will face the ball.
 - > For V-Control valves, insert V-ball with V opening being on right side of the stem, so when valve fully open, V will face downstream seat following flow arrow marked on the body.



CAUTION

Do not use body bolting to align piping. This can damage the valve and cause body seal leakage.



NOTICE

Body bolts/body nuts must be tightened in a cross or star pattern, to prevent uneven loading of the body seal.

14. Install the spring washer on the body bolts.
15. Lubricate threads and the nut faces in contact with the end caps with anti-seize thread lubricant compatible with the media. Install the end caps onto the body with the body bolts. Tighten the body bolts in a cross pattern per **Figure 1** based on number of fasteners per body joint. Fastener torque should be applied at 30%, 60% and 100% and once more at 100% increments per **Table 1**.
16. Cycle the valve slowly several times. By cycling slowly, the seats will conform to the ball. A fast-turning motion initially may damage the seats before they have a chance to form the proper seal.
17. Mount actuation per installation section instructions.

10.8 Valve Assembly Procedures NPS 3 - 4 | DN 80 - 100



NOTICE

Certain valve constructions are uni-directional. A flow arrow will indicate the flow direction. Care should be taken when rebuilding the valve to ensure these special constructions are considered.

1. Hold the body in a vise firmly enough to prevent movement but do not crush or damage the body.

2. Place the stem bearing, thrust washer protector and thrust washer on the stem and slide the stem into the stem hole in the valve body. Be careful not to damage the stem or body.
3. Install the stem packing onto the stem until it is rested against the bottom of the packing bore. See **Figure 3** for proper orientation.
4. Install the packing protector and then the packing gland onto the stem, and top of the stem packing.
5. Install packing follower on top of the packing gland.
6. Install the gland bolts through the packing follower and thread into the body. Fasteners should be hand tight. Lubricate threads and bolt faces in contact with the packing gland with anti-seize thread lubricant compatible with the media.



NOTICE

If valve will be automated, Steps 7 - 10 are not required.

7. Install the travel stop housing over stem. Openings on side of travel stop housing shall be perpendicular to the pipeline.
8. Install the housing bolts through the stop housing and thread into the body. Lubricate threads and the bolt faces in contact with the travel stop housing with anti-seize thread lubricant compatible with the media. Tighten bolts.
9. Install travel stop plate over the stem making sure the lockout holes in the stop housing and travel stop housing are aligned in the open and closed positions.
10. Install snap ring over stem in groove closest to the travel stop housing.
11. Turn the stem until the stem flat is parallel to the port centerline (so that the ball can fit onto the stem).
12. Rotate the stem to the closed position and install the ball inside the valve body. The stem flats will fit into the slot on top of the ball. Lifting aid may be required to install the ball. Be careful not to damage sealing surfaces of ball or body.
 - > For V-Control valves, insert V-ball with V opening being on right side of the stem, so when valve fully open, V will face downstream seat following flow arrow marked on the body.
13. Turn the stem so that the ball is in the open position (the ball will not fall out of the valve).
14. Install the seats inside the body and body seals inside an end cap, make sure the spherical curvature side of the seat will face the ball.
 - > For V-Control valves, insert V-ball with V opening being on right side of the stem, so when valve fully open, V will face downstream seat following flow arrow marked on the body.



CAUTION

Do not use body bolting to align piping. This can damage the valve and cause body seal leakage.



NOTICE

Body bolts/body nuts must be tightened in a cross or star pattern, to prevent uneven loading of the body seal.

15. Install the spring washer on the body bolts.
16. Lubricate threads and the nut faces in contact with the end caps with anti-seize thread lubricant compatible with the media. Install the end caps onto the body with the body bolts. Tighten the body bolts in a cross pattern per **Figure 1** based on number of fasteners per body joint. Fastener torque should be applied at 30%, 60% and 100% and once more at 100% increments per **Table 1**.
17. If equipped with a handle, install handle onto the valve stem and secure the handle with handle bolt. Install snap ring over stem in groove on top of handle.
18. Cycle the valve slowly several times. By cycling slowly, the seats will conform to the ball. A fast-turning motion initially may damage the seats before they have a chance to form the proper seal.
19. Mount actuation per installation section instructions.

10.9 Valve Assembly Procedures NPS 6 and 8 | DN 150 and 200



NOTICE

Certain valve constructions are unidirectional. A flow arrow will indicate the flow direction. Care should be taken when rebuilding the valve to ensure these special constructions are considered.

1. Hold the body in a vise firmly enough to prevent movement but do not crush or damage the body.
2. Place the stem bearing, thrust washer protector and thrust washer on the stem and slide the stem into the stem hole in the valve body. Be careful not to damage the stem or body.
3. Install the stem packing onto the stem until it is rested against the bottom of the packing bore. See **Figure 3** for proper orientation.
4. Install the packing protector and then the packing gland onto the stem, and top of the stem packing.
5. Install packing follower on top of the packing gland.
6. Install the gland bolts through the packing follower and thread into the body. Fasteners should be hand tight. Lubricate threads and bolt faces in contact with the packing follower with anti-seize thread lubricant compatible with the media.



NOTICE

If valve will be automated, Steps 7 - 10 are not required.

7. Install the travel stop housing over stem. Openings on side of stop housing shall be perpendicular to the pipeline.
8. Install the housing bolts through the stop housing and thread into the body. Lubricate threads and the bolt faces in contact with the end caps with anti-seize thread lubricant compatible with the media. Tighten bolts.
9. Install travel stop plate over the stem making sure the lockout holes in the stop housing and travel stop housing are aligned in the open and closed positions.
10. Install snap ring over stem in groove closest to the travel stop housing.
11. Turn the stem until the stem flat is parallel to the port centerline (so that the ball can fit onto the stem).
12. Rotate the stem to the closed position and install the ball inside the valve body. The stem flats will fit into the slot on top of the ball. Lifting aid may be required to install the ball. Be careful not to damage sealing surfaces of ball or body.
 - > For V-Control valves, insert V-ball with V opening being on right side of the stem, so when valve fully open, V will face downstream seat following flow arrow marked on the body.
13. Turn the stem so that the ball is in the open position (the ball will not fall out of the valve).
14. Install the seat supports and seats inside the body and body seals inside an end cap, make sure the spherical curvature side of the seat will face the ball.
 - > For V-Control valves, insert V-ball with V opening being on right side of the stem, so when valve fully open, V will face downstream seat following flow arrow marked on the body.



CAUTION

Do not use body bolting to align piping. This can damage the valve and cause body seal leakage.



NOTICE

Body bolts/body nuts must be tightened in a cross or star pattern, to prevent uneven loading of the body seal.

15. Install the spring washer on the body bolts.
16. Lubricate threads and the nut faces in contact with the end caps with anti-seize thread lubricant compatible with the media. Install the end caps onto the body with the body bolts. Tighten the body bolts in a cross pattern per **Figure 1** based on number of fasteners per body joint. Fastener torque should be applied at 30%, 60% and 100% and once more at 100% increments per **Table 1**.

17. If equipped with a handle, install handle junction onto the valve stem and secure with handle bolt. Install handle into handle junction and secure with handle bolt.
18. Cycle the valve slowly several times. By cycling slowly, the seats will conform to the ball. A fast-turning motion initially may damage the seats before they have a chance to form the proper seal.
19. Mount actuation per installation section instructions.

10.10 Valve Assembly Procedures NPS 10 and 12 | DN 250 and 300



NOTICE

Certain valve constructions are unidirectional. A flow arrow will indicate the flow direction. Care should be taken when rebuilding the valve to ensure these special constructions are considered.

1. Hold the body in a vise firmly enough to prevent movement but do not crush or damage the body.
2. Place the stem bearing, thrust washer protector and thrust washer on the stem and slide the stem into the stem hole in the valve body. Be careful not to damage the stem or body.
3. Install the stem packing onto the stem until it is rested against the bottom of the packing bore. See Figure 3 for proper orientation.
4. Install the packing protector and then the packing gland onto the stem, and top of the stem packing.
5. Install packing follower on top of the packing gland.
6. Install the gland bolts through the packing follower and thread into the body. Fasteners should be hand tight. Lubricate threads and bolt faces in contact with the packing follower with anti-seize thread lubricant compatible with the media.



NOTICE

If valve will be automated, Steps 7 and 8 are not required.

7. Install travel stop plate over the stem making sure the lockout holes in the packing follower and travel stop plate are aligned in the open and closed positions.
8. Install snap ring over stem in groove closest to the travel stop housing.
9. Turn the stem until the stem flat is parallel to the port centerline (so that the ball can fit onto the stem).

10. Rotate the stem to the closed position and install the ball inside the valve body. The stem flats will fit into the slot on top of the ball. Lifting aid may be required to install the ball. Be careful not to damage sealing surfaces of ball or body.
 - > For V-Control valves, insert V-ball with V opening being on right side of the stem, so when valve fully open, V will face downstream seat following flow arrow marked on the body.
11. Turn the stem so that the ball is in the open position (the ball will not fall out of the valve).
12. Install the seat supports and seats inside the body and body seals inside an end cap, make sure the spherical curvature side of the seat will face the ball.



CAUTION

Do not use body bolting to align piping. This can damage the valve and cause body seal leakage.



NOTICE

Body bolts/body nuts must be tightened in a cross or star pattern, to prevent uneven loading of the body seal.

13. Install the spring washer on the body bolts.
14. Lubricate threads and the nut faces in contact with the end caps with anti-seize thread lubricant compatible with the media. Install the end caps onto the body with the body bolts. Tighten the body bolts in a cross pattern per Figure 1 based on number of fasteners per body joint. Fastener torque should be applied at 30%, 60% and 100% and once more at 100% increments per Table 1.
15. If equipped with a handle, install handle junction onto the valve stem and secure with handle bolt. Install handle into handle junction and secure with handle bolt.
16. Cycle the valve slowly several times. By cycling slowly, the seats will conform to the ball. A fast-turning motion initially may damage the seats before they have a chance to form the proper seal.
17. Mount actuation per installation section instructions.

11.0 REPAIR KITS

Only Bray repair parts shall be used to service Bray products. Contact Bray for ordering proper repair kit and any valve replacement parts not provided in the repair kit.

When ordering repair kit and replacement parts, include

1. Valve identification information
2. Valve serial number if provided
3. Replacement part item number, part description and quantity.

12.0 TROUBLESHOOTING

TROUBLE	POSSIBLE CAUSE	SOLUTION
Packing Leakage	Packing Consolidation Packing Wear Improper Repair	Tighten gland bolting or lock nut to eliminate leak. If leak continues follow proper maintenance and repair
Seat Leakage	Seat Wear Media Damage Improper Repair Improper Installation Direction	Follow proper installation maintenance and repair
Body Seal Leakage	Improper Installation or Welding Technique Improper Repair	Tighten body bolts per Table 1 following tightening technique outline in valve assembly section. If leak continues follow proper maintenance and repair

NOTES:

- > Bray does not accept any responsibility for the product if wear parts not tested and approved by Bray are used.
- > Bray does not accept any responsibility for the product if maintenance instructions are not followed during maintenance.

13.0 RETURN MERCHANDISE AUTHORIZATION



WARNING

Before products are returned to Bray for repair or service, Bray must be provided with a certificate that confirms that the product has been decontaminated and is clean.

All products that are returned require a Return Merchandise Authorization (RMA). Contact a Bray representative to obtain authorization and shipping instructions.

The following information must be provided when submitting RMA.

- > Serial number
- > Part number
- > Month and year of manufacture
- > Time of purchase (if known)
- > Actuator and actuator accessories/controls specifics
- > Application
- > Media
- > Operating temperature
- > Operating pressure
- > Total estimated cycles (since last installation or repair)

NOTE: Product information is provided on identification tag attached to device.



NOTICE

Materials must be cleaned and sanitized prior to return. MSDS sheets and Declaration of Decontamination are required.

SINCE 1986, BRAY HAS PROVIDED FLOW CONTROL SOLUTIONS FOR A VARIETY OF INDUSTRIES AROUND THE WORLD.

VISIT **BRAY.COM** TO LEARN MORE ABOUT BRAY PRODUCTS AND LOCATIONS NEAR YOU.

HEADQUARTERS

BRAY INTERNATIONAL, INC.

13333 Westland East Blvd.

Houston, Texas 77041

Tel: +1.281.894.5454

All statements, technical information, and recommendations in this bulletin are for general use only. Consult Bray representatives or factory for the specific requirements and material selection for your intended application. The right to change or modify product design or product without prior notice is reserved. Patents issued and applied for worldwide. Bray® is a registered trademark of Bray International, Inc.

© 2024 BRAY INTERNATIONAL. ALL RIGHTS RESERVED. BRAY.COM

EN_IOM-2301_S7000_8000_09-03-2024



THE HIGH PERFORMANCE COMPANY

BRAY.COM