

**SERIES 70**

**SERVO NXT - DeviceNet™**

Installation, Operation and Maintenance Manual

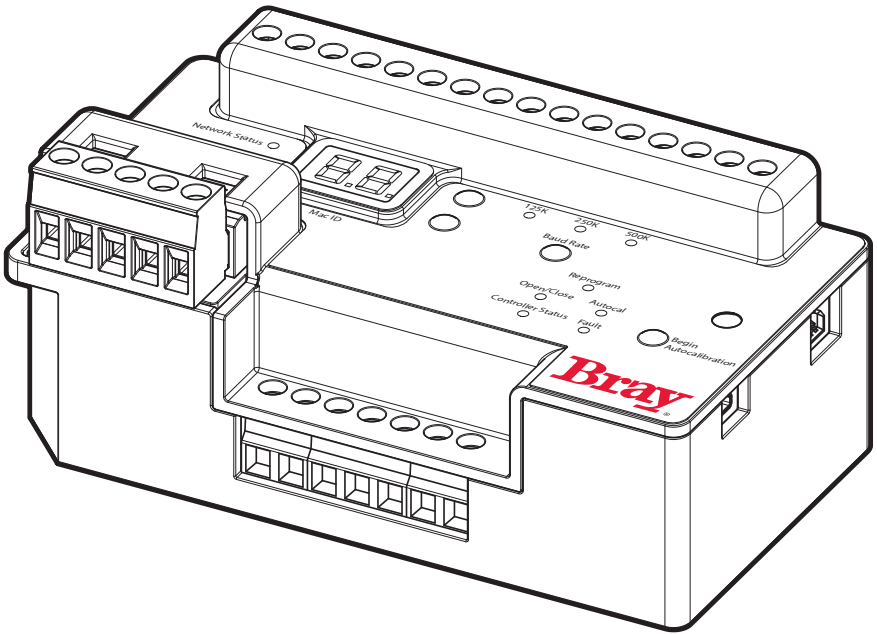

FOR MORE INFORMATION ON THIS PRODUCT AND OTHER BRAY PRODUCTS  
PLEASE VISIT OUR WEBSITE – [www.bray.com](http://www.bray.com)



## Table of Contents

1.0 Safety Instructions - Definition of Terms . . . . .	3
2. Introduction . . . . .	5
2.1 Definition of Terms . . . . .	5
2.2 Description of Operation . . . . .	5
3. Hardware Description . . . . .	5
3.1 User Interface . . . . .	5
3.1.1 LED Indication . . . . .	6
3.1.1.1 Mac ID . . . . .	6
3.1.1.2 Network Status . . . . .	6
3.1.1.3 Module Status . . . . .	7
3.1.1.4 - 125K . . . . .	7
3.1.1.5 - 250K . . . . .	7
3.1.1.6 - 500K . . . . .	7
3.1.1.7 Reprogram . . . . .	7
3.1.1.8 Open/Close . . . . .	7
3.1.1.9 Autocal . . . . .	7
3.1.1.10 Controller Status . . . . .	7
3.1.1.11 Fault . . . . .	7
3.1.2 Switches . . . . .	8
3.1.2.1 Up arrow . . . . .	8
3.1.2.2 Down arrow . . . . .	8
3.1.2.3 Right arrow . . . . .	8
3.1.2.4 Autocalibration . . . . .	8
3.2 Controller Wiring . . . . .	8
3.2.1 Input Power . . . . .	9
3.2.2 Heater . . . . .	9
3.2.3 Motor . . . . .	9
3.2.4 FB Pot . . . . .	9
3.2.5 Cntrl Box . . . . .	9
3.2.6 Handwheel . . . . .	9
3.2.7 Torque Switches . . . . .	9
3.2.8 Limit Switches . . . . .	9
3.2.9 DeviceNet™ Connector . . . . .	9
4. DeviceNet™ Interface . . . . .	10
4.1 DeviceNet™ Network Requirements . . . . .	10
4.1.1 Network connections, terminations, power, and limits . . . . .	10
4.1.2 Network grounding and isolation . . . . .	12
4.1.3 Network power . . . . .	12

4.2 Configuration . . . . .	12
4.3 Commissioning . . . . .	12
4.3.1 EDS (Electronic Data Sheet) . . . . .	12
4.4 Communication . . . . .	13
4.4.1 Polled Message Connection . . . . .	13
4.4.2 Explicit Message Connection . . . . .	13
4.5 Supported Attributes . . . . .	13
4.5.1 Attribute Descriptions . . . . .	15
4.5.1.1 Parameter 1 – Set Valve Position . . . . .	15
4.5.1.2 Parameter 4 – Actuator Operational Status . . . . .	15
4.5.1.3 Parameter 5 – Travel Limit Switch Status . . . . .	15
4.5.1.4 Parameter 6 – Torque Limit Switch Status . . . . .	16
4.5.1.5 Parameter 7 – Actuator Control State . . . . .	16
4.5.1.6 Parameter 8 – Handwheel Switch Status . . . . .	16
4.5.1.7 Parameter 9 – Set Motor Speed Control State . . . . .	16
4.5.1.8 Parameter 10 – Set Motor Speed: Open Direction . . . . .	17
4.5.1.9 Parameter 11 – Set Speed Control Begin: Open Direction . . . . .	17
4.5.1.10 Parameter 12 – Set Speed Control End: Open Direction . . . . .	17
4.5.1.11 Parameter 13 – Set Motor Speed: Close Direction . . . . .	18
4.5.1.12 Parameter 14 – Set Speed Control Begin: Close Direction . . . . .	18
4.5.1.13 Parameter 15 – Set Speed Control End: Close Direction . . . . .	18
4.5.1.14 Parameter 16 – Enable Failure Mode Position . . . . .	19
4.5.1.15 Parameter 17 – Set Failure Mode Position . . . . .	19
4.5.1.16 Parameter 18 – Set Motor Instantaneous Reversal Delay . . . . .	19
4.5.1.17 Parameter 19 – Set Position Deadband . . . . .	19
4.5.1.18 Parameter 20 – Set Torque Limit State . . . . .	20
4.5.1.19 Parameter 21 – Set Torque Limit State . . . . .	20
4.5.1.20 Parameter 22 – Set Autocalibration Mode . . . . .	20
4.5.1.21 Parameter 23 – Fault Status . . . . .	21
4.5.1.22 Parameter 24 – Local Control Switch Status . . . . .	21
4.5.1.23 Parameter 25 – Set Data Configuration . . . . .	22
5. Quick Start guide . . . . .	23
5.1 Start-up sequence . . . . .	23
5.2 Calibration . . . . .	23

## 1.0 Safety Instructions - Definition of Terms

**READ AND FOLLOW THESE INSTRUCTIONS  
 SAVE THESE INSTRUCTIONS**

	<b>WARNING</b>	Indicates a potentially hazardous situation which, if not avoided, <b>could</b> result in death or serious injury.
	<b>CAUTION</b>	Indicates a potentially hazardous situation which, if not avoided, may result in minor or moderate injury.
<b>NOTICE</b>		Used without the safety alert symbol indicates a potential situation which, if not avoided, may result in an undesirable result or state, including property damage.

### 1.1 Hazard-free Use

This device left the factory in proper condition to be safely installed and operated in a hazard-free manner. The notes and warnings in this document must be observed by the user if this safe condition is to be maintained and hazard-free operation of the device assured.

Take all necessary precautions to prevent damage to the device due to rough handling, impact, or improper storage. Do not use abrasive compounds to clean the device, or scrape its surfaces with any objects.

Configuration and calibration procedures are described in this document. Proper configuration and calibration is required for the safe operation of the device.

The control system in which the device is installed must have proper safeguards to prevent injury to personnel, or damage to equipment, should failure of system components occur.

This document does not cover every detail about every version of the product described. It cannot take into account every potential occurrence in installation, operation, maintenance and use.

If situations transpire that are not documented in sufficient detail, please request the required information from the Bray distributor or representative responsible for your area.

### 1.2 Qualified Personnel

A qualified person in terms of this document is one who is familiar with the installation, commissioning and operation of the device and who has appropriate qualifications, such as:

- Is trained in the operation and maintenance of electric equipment and systems in accordance with established safety practices
- Is trained or authorized to energize, de-energize, ground, tag and lock electrical circuits and equipment in accordance with established safety practices
- Is trained in the proper use and care of personal protective equipment (PPE) in accordance with established safety practices
- Is trained in first aid
- In cases where the device is installed in a potentially explosive (hazardous) location – is trained in the operation, commissioning, operation and maintenance of equipment in hazardous locations



## **WARNING**

The device must only be installed, commissioned, operated and repaired by qualified personnel.

The device is designed for installation inside the Bray S70 Electric Actuator, and to position an industrial quarter-turn valve. It must be installed according to its intended purpose.

The device controls the movement of an electric actuator that generates large mechanical forces.

To prevent injury, installation, commissioning, operation and maintenance must be carried out under strict observation of the applicable safety regulations.

The specifications of the examination certificate valid in the applicable country must be observed. This includes the actuator in which the device is installed.

Verify that the main electric power supplied to the device is compliant with the specifications on the product label and the specifications in the examination certificate valid in the applicable country.

Avoid electrostatic discharges within hazardous areas.

The housings and external connections on the actuators (in which the device is installed) may only be opened after all electrical power to the actuator has been removed.

Correct and safe operation of the device is dependent upon proper transport, storage and installation in addition to proper operation and maintenance.

## **1.3 Intended Use**

The device described in this guide has been developed, manufactured, tested and documented with all relevant safety standards taken into account. If the handling rules and safety information for configuration, calibration, installation and maintenance are observed, and the product is used for its intended purpose, there is normally no danger with regard to material damage or personnel health.

## **1.4 Warranty Information**

The content of this document is not part of, and does not modify, a previous or current agreement, undertaking or legal relationship. Bray Controls is bound solely by the contract of sale, which also contains the complete and exclusive warranty. The contractual warranty conditions are neither extended nor restricted by this document.

## 2. Introduction

The Bray Series 70 Servo NXT - DeviceNet™ is a bus-based controller that provides complete control and monitoring of the Bray Series 70 Electric Actuator. It accomplishes this by interfacing with a DeviceNet™ network, over which commands can be received and feedback can be returned. Once connected to the DeviceNet™ network, the Bray Series 70 Servo NXT - DeviceNet™ becomes part of a larger system, which is required to ensure proper use of the device. To refer to the elements of the system, a common terminology is used throughout this document, as defined below.

### 2.1 Definition of Terms

- Actuator Controller – Bray Series 70 Servo NXT - DeviceNet™
- Actuator – Bray Series 70 Quarter-Turn Electric Actuator
- Process Controller – Device that communicates with the Actuator Controller via the DeviceNet™ network. The Process Controller acts as the Master on the DeviceNet™ Network.

### 2.2 Description of Operation

The function of the Actuator Controller is to position the Actuator in response to commands from the Process Controller. As the Actuator position changes, the attached valve creates a change in the flow of the medium that it controls. This change in medium

flow rate is referred to as a process variable. As the Process Controller monitors this process variable, it is able to adjust the commands sent to the Actuator Controller to achieve the optimal position(s) for the process.

These commands come in the form of DeviceNet™ messages, which follow a predefined format as established by the ODVA (Open DeviceNet™ Vendor Association, Inc.) in the CIP (Common Industrial Protocol) standards. The Process Controller must be configured beforehand to properly interface with the Actuator Controller and ensure the correct information is exchanged. Refer to section 5 for information on the DeviceNet™ interface.

## 3. Hardware Description

### 3.1 User Interface

The Actuator Controller features a full user interface providing control and status of the device. This section details all aspects of the user interface and their function. Refer to Figure 1 throughout section 3.1.

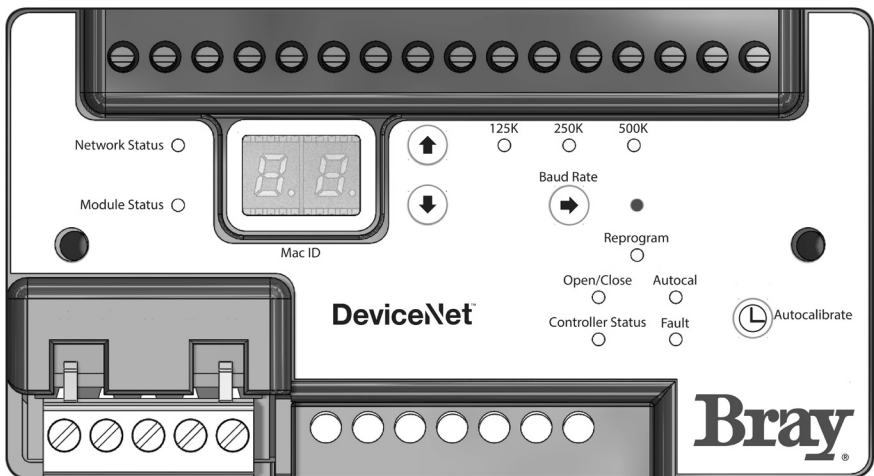

Figure 1: S70 Servo NXT - DeviceNet™

### 3.1.1 LED Indication

#### 3.1.1.1 Mac ID

Shows the current Node Address for the Actuator Controller. Refer to the switch section for information on changing this value.

In the event of a fault, this display will alternate between the current Node Address and the Active Fault Code. The Active Fault Code aligns with the fault codes listed for DeviceNet™ parameter 23, Fault Status. They are listed here for reference:

E1 – Miswire – Check actuator wiring

E2 – Motor Stall – Motor is not moving the actuator as expected

E3 – Feedback Fault – Position feedback is out-of-range

E4 – Temperature Fault – Controller has exceeded safe operating temperature

E5 – AutoCal Fault - Autocalibration has failed to complete

E6 – Limit SW Fault - Limit Switches are miswired

E7 – Overtorque – Actuator has exceeded its operational torque limits

E8 – Handwheel - Handwheel is engaged

E9 – Error - Controller requires reset

#### 3.1.1.2 Network Status

See Table 1 below for more information.

**Table 1 - Network Status LED**

For this state:	LED is:	To indicate:
Not Powered/Not On-line	Off	Device is not on-line. - The device has not completed the Dup_MAC_ID test yet. - The device may not be powered, look at Module Status LED. - No network power present.
On-line, Not Connected	Flashing Green <sup>1</sup>	Device is on-line but has no connections in the established state. - The device has passed the Dup_MAC_ID test, is on-line, but has no established connections to other nodes. - For a Group 2 Only device it means that this device is not allocated to a master. - For a UCMM capable device it means that the device has no established connections
Link OK On-line, Connected	Green	The device is on-line and has connections in the established state. - For a Group 2 Only device it means that the device is allocated to a Master. - For a UCMM capable device it means that the device has one or more established connections.
Connection Time-Out	Flashing Red <sup>1</sup>	One or more I/O Connections are in the Timed-Out state.
Critical Link Failure	Red	Failed communication device. The device has detected an error that has rendered it incapable of communicating on the network. (Duplicate MAC ID, or Bus-off).
Communication Faulted and Received an Identify Comm Fault Request - Long Protocol	Flashing Red & Green <sup>2</sup>	A specific Communication Faulted device. The device has detected a Network Access error and is in the Communication Faulted state. The device has subsequently received and accepted an Identify Communication Faulted Request - Long Protocol message.

<sup>1</sup> For information on LED flash rates, refer to section 9-2.8

<sup>2</sup> For information on LED flash rates, refer to Chapter 2, section 2-11.4.3



### 3.1.1.3 Module Status

See Table 2 below for more information.

**Table 2 - Module Status LED**

For this state:	LED is:	To indicate:
No Power	Off	There is no power applied to the device.
Device Operational	Green	The device is operating in a normal condition.
Device in Standby (The Device Needs Commissioning)	Flashing Green <sup>1</sup>	The device needs commissioning due to configuration missing, incomplete or incorrect. The Device may be in the Standby state. Reference the Identity Object in Volume 1, Chapter 5: Object Library.
Recoverable Fault	Flashing Red <sup>1</sup>	The device has a recoverable fault.
Unrecoverable Fault	Red	The device has an unrecoverable fault; may need replacing.
Device Self Testing	Flashing Red-Green <sup>1</sup>	The Device is in Self Test. Reference the Identity Object in Volume II for Device states.

<sup>1</sup> For information on LED flash rates, refer to section 9-2.8

*Page 9-3 of The CIP Networks Library, Volume 3, DeviceNet™ Adaptation of CIP, Ed. 1.14, Nov. 2013*

#### 3.1.1.4 - 125K

When illuminated, indicates that the Actuator Controller is communicating at a data rate of 125Kbaud. Refer to the switch section for information on changing this value.

#### 3.1.1.5 - 250K

When illuminated, indicates that the Actuator Controller is communicating at a data rate of 250Kbaud. Refer to the switch section for information on changing this value.

#### 3.1.1.6 - 500K

When illuminated, indicates that the Actuator Controller is communicating at a data rate of 500Kbaud. Refer to the switch section for information on changing this value.

#### 3.1.1.7 Reprogram

When flashing, indicates that the Actuator Controller is attempting to reboot for reprogramming purposes

#### 3.1.1.8 Open/Close

**Green flashing** – Indicates that the Actuator motor is being energized to open the valve

**Green steady** – Indicates that the Actuator has fully opened the valve

**Red flashing** – Indicates that the Actuator motor is being energized to close the valve

**Red steady** – Indicates that the Actuator has fully closed the valve

#### 3.1.1.9 Autocal

**White flashing** – Actuator Controller is in Autocalibration mode and the motor is stationary.

**White steady** – Actuator Controller is in Autocalibration mode and the motor is rotating.

#### 3.1.1.10 Controller Status

Flashing light that indicates that the Actuator Controller is operating normally.

#### 3.1.1.11 Fault

Illuminates when there is a fault condition. Refer to the section 3.1.1.1 for more information on the fault state.

## 3.1.2 Switches

### 3.1.2.1 Up Arrow

When held for 1 second, allows the Mac ID to be adjusted. The Mac ID value will flash to indicate that it is adjustable. Pressing the up arrow while the Mac ID is adjustable will increase the Mac ID by 1. If the up or down arrow is not pressed for 3 seconds, then the Mac ID will exit the adjustable state, retaining its last value.

### 3.1.2.2 Down Arrow

When held for 1 second, allows the Mac ID to be adjusted. The Mac ID value will flash to indicate that it is adjustable. Pressing the down arrow while the Mac ID is adjustable will decrease the Mac ID by 1. If the up or down arrow is not pressed for 3 seconds, then the Mac ID will exit the adjustable state, retaining its last value.

Valid Mac ID range: 0-63

### 3.1.2.3 Right Arrow

When held for 1 second, allows the Baud Rate to be adjusted. The Baud Rate value will flash to indicate that it is adjustable. Pressing the right arrow while the Baud Rate is adjustable will move the Baud Rate value to the next highest option. If the right arrow is not pressed for 3 seconds, then the Baud Rate will exit the adjustable state, retaining its last value.

Valid Baud Rates: 125K, 250K, and 500K baud

### 3.1.2.4 Autocalibration

Pressing and releasing this button will cause the Actuator Controller to enter Autocalibration mode.

## 3.2 Controller Wiring

For the Actuator Controller to operate the Actuator correctly, the unit must be connected to the Actuator components to energize the motor and monitor operation. This section details how these Actuator components are terminated into the controller. Refer to Figure 2 throughout section 2.2.

All connections not referenced are factory connections and should not be used. Refer to the actuator wiring diagram for locations of preexisting component wire terminations, and also refer to the Series 70 O&M manual for further explanation on the proper installation and usage of actuator components. See Figure 3 for an example wiring diagram.

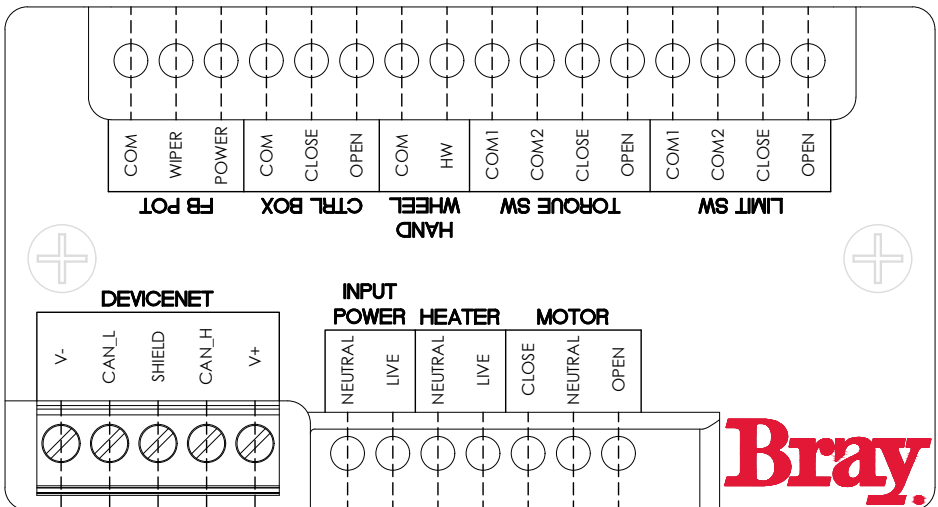

Figure 2: Servo NXT - DeviceNet™ - Wiring Designations

### 3.2.1 Input Power

Power connection that energizes the Actuator Controller and provides power to the Actuator motor. Connection should provide the standard North American supply voltage: Single-phase 120VAC +/- 10%, 60Hz. The controller has an onboard protective fuse rated to 5A, so the power connection should be able to provide at least this much current.

### 3.2.2 Heater

If the Series 70 actuator has an internal heater, then the heater wires should be terminated at this connection.

### 3.2.3 Motor

Connections for the motor that operates the Actuator.

- CLOSE – Red Wire
- NEUTRAL – Yellow or Black Wire
- OPEN – Blue Wire

### 3.2.4 FB Pot

Connections for the Feedback Potentiometer, used by the controller to determine the position of the valve..

- COM – White Wire
- WIPER – Orange Wire
- POWER – Grey Wire

### 3.2.5 Cntrl Box

Connections for the control box, if present. The control box allows for local operation of the Actuator, overriding commands from the DeviceNet™ network.

- COM – Green Wire
- CLOSE – Red Wire
- OPEN – Blue Wire

### 3.2.6 Handwheel

Connections for the handwheel override switch. When the Actuator handwheel is engaged (pulled out), this switch prevents the Actuator from operating until the handwheel is disengaged.

- COM & HW – Yellow Wire

### 3.2.7 Torque Switches

Connections for the mechanical torque switch assembly. These switches alert the Actuator Controller to the occurrence of excessive torque on the Actuator mechanical components.

- COM1 & CLOSE – Red Wire
- COM2 & OPEN – Blue Wire

### 3.2.8 Limit Switches

Connections for the travel limit switches. These switches prevent the Actuator from operating the valve outside the acceptable range of travel.

- COM1 & CLOSE – Red Wire
- COM2 & OPEN – Blue Wire

### 3.2.9 DeviceNet™ Connector

Male Open Connector which provides the DeviceNet™ network connection point for the device. This connector pinout is in alignment with the current CIP standards, and the required customer wiring is provided below.

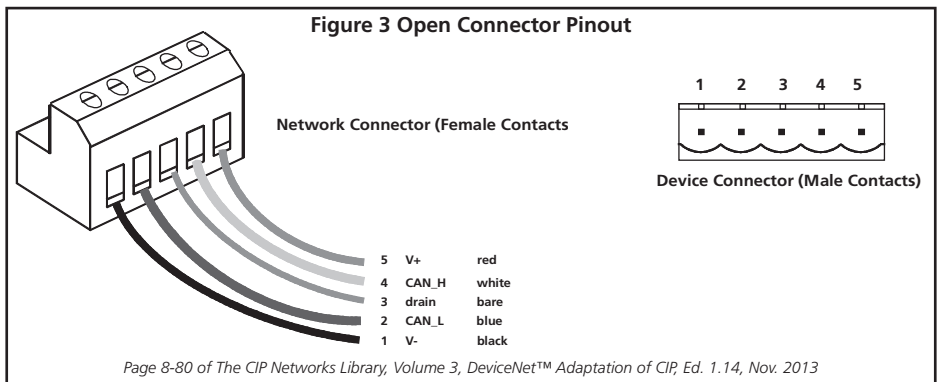

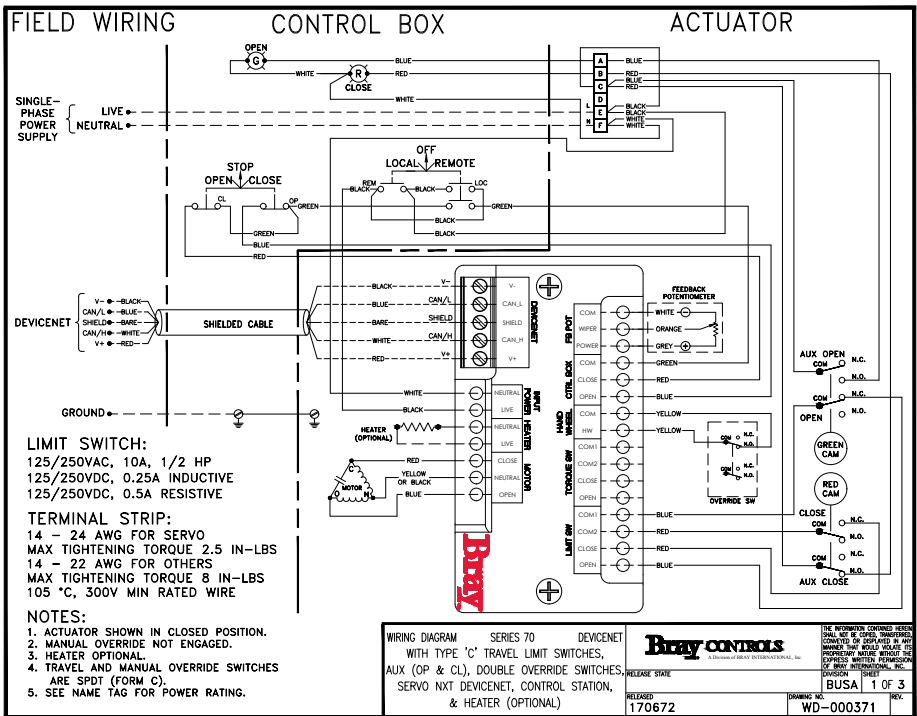

Figure 4: Servo NXT - DeviceNet™ - Example Wiring Diagram

## 4. DeviceNet™ Interface

### 4.1 DeviceNet™ Network Requirements

All information provided in this manual on DeviceNet™ network requirements is for reference only. For the full ODVA requirements, refer to Publication 27R1, Planning and Installation Manual, DeviceNet™ Cable System, which is freely available on the ODVA website ([www.odva.org](http://www.odva.org)). In the event that the information in the two documents are divergent, information and requirements in the ODVA documentation supersedes the information in this document.

#### 4.1.1 Network Connections, Terminations, Power, and Limits

Devices on the network are connected as shown in Figure 2. The network consists of two types of cable; a trunk-line cable and a drop cable. The Trunk line cable is a thicker cable that spans the length of the network. A device is attached to the Trunk line directly by using either a Tap or indirectly by using a Tap and a drop cable. The Drop cable is not as thick as the Trunk line and is only used to connect a single device to the bus.

A terminator of 121 ohms is required at each extreme end of the trunk. The terminator is attached to the end of the trunk and not to the end of a cable drop.

The resistor requirements are:

- 121 ohm
- 1% Metal Film
- 1/4 Watt

Terminating resistors should never be included in nodes. Inclusion of this capability could easily lead to a network with improper termination (too high or too low an impedance) potentially causing failure. For example, removal of a node that includes a terminating resistor could result in network failure.

Devices along the truck-line are attached with Taps (Figure 3) so that any device can be removed or replaced without disconnecting the trunk-line. This feature provides the ability to interchange devices on a network while it is operational reducing network downtime.

Both the trunk-line and drop cables consist of 4 wires and a shield. The trunk-line and drop cable are limited in length and are also effected by the speed of the network.

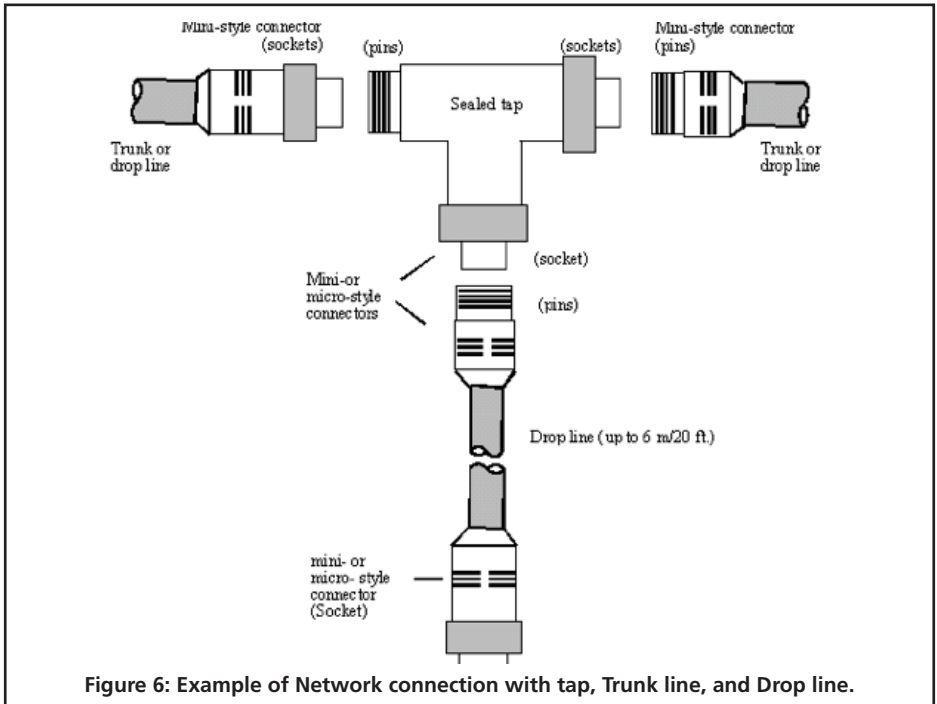
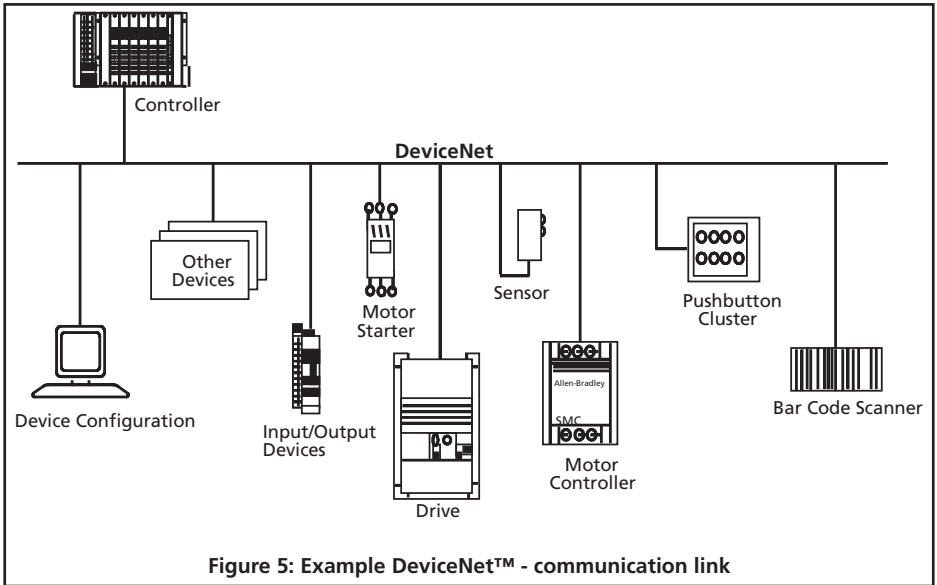

### 4.1.2 Network Grounding and Isolation

DeviceNet™ should be grounded at ONE location. Grounding at more than one location may produce ground loops, while not grounding the network will increase sensitivity to ESD and outside noise sources. Grounding near the physical center of the network is desired.

The trunk drain/shield should be attached to the power supply ground or V with a copper conductor that is either solid, stranded, or braided. Use a 1" copper braid or a #8 AWG wire that is less than 3 meters/10 feet in length. This should then be attached to a good earth or building ground (such as an 8 foot stake driven into the ground, attached to building iron or to the cold water plumbing).

If the network is already grounded, do NOT connect the grounding terminal of the tap or ground of the supply to earth. If more than one supply is on the network, then connect the drain wire/shield at ONE supply only, preferably near the physical center of the network.

### 4.1.3 Network Power

DeviceNet™ has a single supply current capability of up to 16 amps using a thick cable trunk line, and up to 6 amps using a thin cable trunk line, which makes the network highly functional and cost effective.

Power configuration is adjustable based on your system requirements. The DeviceNet™ power bus is supplied by a nominal 24 volt source and can support up to 8 amps on any section of thick cable trunk line or up to 3 amps on any section of thin cable trunk line. Since this much current can be drawn from each side of a power tap, a single supply network can possibly provide twice these current levels. If the system has even greater requirements, DeviceNet<sup>®</sup> can support multiple power supplies.

The network power supply can be placed at the end or at the center of the network. By examining the current requirements of the network, the power supply should be placed such that the maximum current specification is not exceeded.

The selection of the power supply should ensure a tolerance of +24 VDC +/- 1% and current capability of 016 amps.

## 4.2 Configuration

When adding the Actuator Controller to a DeviceNet™ network, it must be configured with the correct network Baud Rate and it must also

have a unique Mac ID. The Actuator Controller should not be added to an existing network until the MAC ID and Baud rate have been properly set. If the Actuator Controller is added to a network with either a conflicting MAC ID or incorrect Baud rate, the network will not be effected, but the Actuator Controller will be taken offline as indicated by a solid red color on the Network LED. The unit must then be removed from the network and then added after the conflicts have been resolved.

If the MAC ID or Baud Rate needs to be changed, then the unit should be powered on with AC power, allowing the necessary changes to be made before connecting the device to the DeviceNet™ network.

### 4.3 Commissioning

Commissioning is the process of taking the Actuator Controller from the on-line state to establishing a dedicated connection with a master on the network. The controller supports a Polled network connection and an Explicit message connection. These connections are supported simultaneously but only one connection of each type is supported at a time.

When the controller transitions from the On-line state to the Commissioned state, the Network LED will change from flashing green to a solid green. When the Master / Slave relationship is released, the Network Led will return to a flashing green.

The Process Controller needs to have the information contained in the EDS file of the Actuator Controller referenced before commissioning will occur.

#### 4.3.1 EDS (Electronic Data Sheet)

An EDS (Electronic Data Sheet) is an external file that contains information about configurable attributes for a device, including object addresses of each parameter. The EDS provides the user with a simple to use interface for configuring and monitoring a device.

The EDS file is included with the Actuator Controller to aide in commissioning. Products such as the Process Controller will use the EDS to automatically obtain the data that is required for configuration. When the Actuator Controller EDS file is accessed through an application, all of the parameters available for monitoring and configuration are displayed. EDS parameters which are settable can be modified and saved to the Actuator Controller.

Depending upon the EDS enabled application that is used, features such as monitoring are available

which provide the user with a continuously updated display the selected parameter group.

#### 4.4 Communication

All communication with the Actuator Controller takes place over the DeviceNet™ network. The DeviceNet™ interface gives the user the ability to control and monitor the Actuator Controller.

The Actuator Controller supports standard DeviceNet™ Polled and Explicit messaging connections.

##### 4.4.1 Polled Message Connection

A polled message connection provides a Process Controller with the ability to rapidly send and receive short messages to all devices on a network in a “polled” fashion. This is typically the main communication mode of a Process Controller.

The Polled message sent by the master must be 2 bytes and corresponds to a requested valve position. The Actuator Controller responds with 2 bytes, which corresponds to the current valve position, plus the option to include status bits. See Parameter 25 in the Supported Attributes section.

##### 4.4.2 Explicit Message Connection

An explicit message connection provides the Master with the ability to directly access a particular parameter that is supported by the Actuator Controller. These parameters are accessed by using the “GET” or “SET” DeviceNet™ attribute service. As an example, an Explicit Message can be used to position the valve and set the supported attributes.

#### 4.5 Supported Attributes

The Actuator Controller supports attributes in Application Class 100, Instance 1, which provide access to the features that are also accessible in the EDS (Electronic Data Sheet). These attributes are provided in the event the user wishes to monitor or control aspects of the controller beyond a polled message connection.

A Process Controller will typically access the Actuator Controller through a polled message connection. A polled message connection only sends and receives the Actuator Controller actuator position. To monitor or control additional features of the Actuator Controller, an explicit message must be sent to the appropriate attribute.

All attributes can be read (GET service) and set (SET Service) unless otherwise noted. As an example, attribute 100, Valve position, if “SET” would position the valve, if the attribute were read (GET), the present valve position would be returned.

The EDS (Electronic Data Sheet) file, which is provided with the Actuator Controller, contains the most current information pertaining to attribute data. Use the EDS as a reference for data types, data formats, and data conversion. Also check the Bray website to obtain the latest EDS file for the Actuator Controller ([www.bray.com](http://www.bray.com)).

**Table 3: S70 Servo NXT - DeviceNet™ supported attributes**

Param	Attribute Description	Attribute (Hex)	Attribute (Decimal)
1	Set Valve Position	0x64	100
4	Actuator Operational Status <sup>1</sup>	0x67	103
5	Travel Limit Switch Status <sup>1</sup>	0x69	105
6	Torque Limit Switch Status <sup>1</sup>	0x72	114
7	Actuator Control State <sup>1</sup>	0x68	104
8	Handwheel Switch Status <sup>1</sup>	0x71	113
9	Set Motor Speed Control State	0x73	115
10	Set Motor Speed: Open Direction	0x74	116
11	Set Speed Control Begin: Open Direction	0x75	117
12	Set Speed Control End: Open Direction	0x76	118
13	Set Motor Speed: Close Direction	0x77	119
14	Set Speed Control Begin: Close Direction	0x78	120
15	Set Speed Control End: Close Direction	0x79	121
16	Set Failure Mode Position Control State	0x7A	122
17	Set Failure Mode Return Position	0x7B	123
18	Set Instantaneous Motor Reversal Delay	0x7C	124
19	Set Position Deadband	0x90	144
20	Set Torque Limit State	0x91	145
21	Serial Number <sup>1</sup>	0xC0	192
22	Set Autocalibration Mode	0x88	136
23	Fault Status <sup>1</sup>	0xC3	195
24	Local Control Switch Status <sup>1</sup>	0x70	112
25	Set Data Configuration	0xC5	197

*1 Attributes which are read-only.*



## 4.5.1 Attribute Descriptions

### 4.5.1.1 Parameter 1 – Set Valve Position

Attribute	100
Size	2 bytes
Read/Write	RW
Range	0-100% (0-4096)
Description	Determines the position of the actuator. 0% - Fully Closed (default) 100% - Fully Open

### 4.5.1.2 Parameter 4 – Actuator Operational Status

Attribute	103
Size	1 byte
Read/Write	R
Description	Provides the current operational status of the actuator. 0 – Stopped 1 – Opening 2 – Closing 3 – Calibrating

### 4.5.1.3 Parameter 5 – Travel Limit Switch Status

Attribute	105
Size	1 byte
Read/Write	R
Description	Provides feedback on the position of the actuator, based on the state of the limit switches. 0 – Actuator at midtravel position 1 – Actuator Open 2 – Actuator Closed 3 – Limit Switch Fault

#### 4.5.1.4 Parameter 6 – Torque Limit Switch Status

Attribute	114
Size	1 byte
Read/Write	R
Description	Provides the status of the torque limit switches.  0 – Normal 1 – Open direction torque limit reached 2 – Close direction torque limit reached

#### 4.5.1.5 Parameter 7 – Actuator Control State

Attribute	104
Size	1 byte
Read/Write	R
Description	Indicates whether the actuator is being controlled remotely via the DeviceNet™ network or locally from a control station.  0 – Remote 1 – Local

#### 4.5.1.6 Parameter 8 – Handwheel Switch Status

Attribute	113
Size	1 byte
Read/Write	R
Description	Provides the state of the Actuator handwheel.  0 – Disengaged (Pushed In) 1 – Engaged (Pulled Out)

#### 4.5.1.7 Parameter 9 – Set Motor Speed Control State

Attribute	115
Size	1 byte
Read/Write	RW
Description	Determines whether the running speed of the actuator is limited to a user defined value.  0 – Disabled 1 – Enabled

#### 4.5.1.8 Parameter 10 – Set Motor Speed: Open Direction

Attribute	116
Size	1 byte
Range	1-100% (1-255)
Read/Write	RW
Description	<p>If Parameter 9 is enabled, sets the Actuator operating speed in the open direction. This value is percentage of full speed.</p> <p>1% – Minimum Speed</p> <p>100% – Full Speed (default)</p>

#### 4.5.1.9 Parameter 11 – Set Speed Control Begin: Open Direction

Attribute	117
Size	1 byte
Read/Write	RW
Range	0-100% (0-255)
Description	<p>If Parameter 9 is enabled, sets the position where speed limiting begins in the open direction.</p> <p>0% – Fully Closed Position (default)</p> <p>100% – Fully Open Position</p>

#### 4.5.1.10 Parameter 12 – Set Speed Control End: Open Direction

Attribute	118
Size	1 byte
Read/Write	RW
Range	0-100% (0-255)
Description	<p>If Parameter 9 is enabled, sets the position where speed limiting ends in the open direction.</p> <p>0% – Fully Closed Position</p> <p>100% – Fully Open Position (default)</p>

#### 4.5.1.11 Parameter 13 – Set Motor Speed: Close Direction

Attribute	119
Size	1 byte
Read/Write	RW
Range	1-100% (1-255)
Description	<p>If Parameter 9 is enabled, sets the Actuator operating speed in the close direction. This value is percentage of full speed.</p> <p>1% – Minimum Speed 100% – Full Speed (default)</p>

#### 4.5.1.12 Parameter 14 – Set Speed Control Begin: Close Direction

Attribute	120
Size	1 byte
Read/Write	RW
Range	0-100% (0-255)
Description	<p>If Parameter 9 is enabled, sets the position where speed limiting begins in the close direction.</p> <p>0% – Fully Closed Position 100% – Fully Open Position (default)</p>

#### 4.5.1.13 Parameter 15 – Set Speed Control End: Close Direction

Attribute	121
Size	1 byte
Read/Write	RW
Range	0-100% (0-255)
Description	<p>If Parameter 9 is enabled, sets the position where speed limiting ends in the close direction.</p> <p>0% – Fully Closed Position (default) 100% – Fully Open Position</p>

#### 4.5.1.14 Parameter 16 – Enable Failure Mode Position

Attribute	122
Size	1 byte
Read/Write	RW
Description	Determines if the actuator has a return position in the event of a DeviceNet™ communication failure.  0 – Disabled (default) 1 – Enabled

#### 4.5.1.15 Parameter 17 – Set Failure Mode Position

Attribute	123
Size	1 byte
Read/Write	RW
Range	0-100% (0-255)
Description	If Parameter 16 is enabled, sets the position where the actuator will position itself in the event of a DeviceNet™ communication failure.  0% – Fully Closed Position (default) 100% – Fully Open Position

#### 4.5.1.16 Parameter 18 – Set Motor Instantaneous Reversal Delay

Attribute	124
Size	1 byte
Read/Write	RW
Range	0.5 - 25.5 seconds (5-255)
Description	Determines the delay in seconds before the Actuator motor will reverse its direction of travel.  Default – 1.0 second

#### 4.5.1.17 Parameter 19 – Set Position Deadband

Attribute	144
Size	1 byte
Read/Write	RW
Range	1-20% (10-200)
Description	Determines the acceptable offset between the position command and the current position of the actuator.  Default – 1%

#### 4.5.1.18 Parameter 20 – Set Torque Limit State

Attribute	145
Size	1 byte
Read/Write	RW
Description	Determines the acceptable offset between the position command and the current position of the actuator. 0 – Disabled (default) 1 – Enabled

#### 4.5.1.19 Parameter 21 – Set Torque Limit State

Attribute	192
Size	4 bytes
Read/Write	R
Description	Provides the factory assigned serial number for the unit.

#### 4.5.1.20 Parameter 22 – Set Autocalibration Mode

Attribute	136
Size	1 byte
Read/Write	RW
Description	Enable to begin the autocalibration sequence. This bit will be automatically disabled once autocalibration has begun. 0 – Disabled (default) 1 – Enabled

#### 4.5.1.21 Parameter 23 – Fault Status

Attribute	195
Size	1 byte
Read/Write	R
Description	<p>Displays the status of any active faults affecting actuator operation.</p> <ul style="list-style-type: none"> <li>0 – Normal</li> <li>1 – Motor Miswire</li> <li>2 – Motor Stall</li> <li>3 – Feedback Fault</li> <li>4 – Temperature Fault</li> <li>5 – AutoCal Fault</li> <li>6 – Limit Switch Fault</li> <li>7 – Overtorque</li> <li>8 – Handwheel Fault</li> <li>9 - Error</li> </ul>

#### 4.5.1.22 Parameter 24 – Local Control Switch Status

Attribute	112
Size	1 byte
Read/Write	R
Description	<p>Indicates if a position command has been received from the local control station.</p> <ul style="list-style-type: none"> <li>0 – Normal</li> <li>1 – Force Open</li> <li>2 – Force Close</li> </ul>

#### 4.5.1.23.Parameter 25 – Set Data Configuration

Attribute	197
Size	1 byte
Read/Write	RW
Description	<p>Determines the composition of the polled messages sent to the Process Controller, aka the producing connection.</p> <p>0 – Legacy (default)          Producing connection contains 12 bits of data, right-aligned, providing the valve position. Leading 4 bits are unused.</p> <p>1 – Normal          Producing connection contains both valve position data and status information.          Bits 0-11: Parameter 1 – Set Valve Position          Bits 12 &amp; 13: Parameter 5 – Travel Limit Switch Status          Bit 14: Parameter 7 - Actuator Control State          Bit 15: Parameter 8 – Handwheel Switch Status</p>



## 5. Quick Start guide

### 5.1 Start-up Sequence

To provide the upmost in reliability, the S70 Servo NXT – DeviceNet™ controller is fully isolated from the DeviceNet™ network, protecting it from network emissions. This requires that the controller is powered separately from the network, and requires a specific power up sequence for proper operation. The recommended sequence to start the S70 is as follows:

1. Apply AC power to the Series 70 Actuator.
2. The controller will individually light all LEDs as part of its initialization procedure. Once a valid Mac ID is displayed, initialization is complete.
3. Set the S70 Servo NXT – DeviceNet™ MAC ID and Baud Rate using the switches provided on the device.
4. The DeviceNet™ network must be powered and connected to the Series 70 Open Style Connector with proper network termination.
5. If the network is running, the Network LED should begin to flash green at ½ second intervals. This indicates that the S70 has recognized the DeviceNet™ bus, and is ready to be commissioned.

### 5.2 Calibration

The S70 calibration defines the limits of operation of the Series 70 Actuator between the open valve position and the closed valve position. The S70 calibration is flexible and does not require that the valve be at the full opened or closed position to define the calibration end points. The cams on the Series 70, which define the opened and closed positions of the valve, are adjustable to the user's requirements and can be set at any location. The only exception is that the open cam limit setting must correspond to a valve position that is more open than the cam which defines the closed limit valve position.

To commence with Auto Calibration, do the following:

1. Before entering the calibration mode, adjust the open and close limit cams on the Series 70 to the desired position. See the Series 70 O&M manual for more information.
2. Press and release the Autocalibration switch.
3. Autocalibration will begin. This is indicated by the Autocal LED illuminating. Allow autocalibration to run until the Autocal LED turns off.
4. A fault condition will cause Autocalibration to fail.
5. The Auto Calibration mode can be aborted at anytime by engaging the Handwheel.

The Auto Calibration will fail under the following conditions:

1. The Handwheel is engaged (pulled outward).
2. The Opened or Closed Limit switch cams are incorrectly set.
3. A Torque Limit switch is activated during the calibration.
4. The position feedback potentiometer is not plugged into the S70 or is incorrectly oriented.
5. The motor is not wired correctly.







BRAY FLOW CONTROL SOLUTIONS ARE AVAILABLE FOR A VARIETY OF INDUSTRIES.

**ENERGY**

Mining  
Oil & Gas  
Power / FGD  
Nuclear Power

**WATER**

Water / Wastewater  
Ultra Pure Water  
Desalination  
Irrigation

**INDUSTRIAL**

Chemical  
Pulp & Paper  
Textile  
Marine

**INFRASTRUCTURE**

Beverage & Food  
Transportation  
Heating, Ventilation & Air Conditioning (HVAC)



**US HEADQUARTERS**

**Bray International, Inc.**  
13333 Westland East Blvd.  
Houston, Texas 77041  
Tel: 281.894.5454

**CHINA HEADQUARTERS**

**Bray Controls (ZheJiang) Co. Limited**  
98 GaoXin # 6 Road  
XiaoShan Economic & Development Zone  
HangZhou, ZheJiang 311231, P.R. China  
Tel: 86 571 8285 2200

**EUROPE HEADQUARTERS**

**Bray Armaturen & Antriebe Europa**  
Halskestraße 25  
47877 Willich  
Germany  
Tel: +49 2154 8875-0

**INDIA HEADQUARTERS**

**Bray Controls India Pvt. Ltd.**  
Plot No. H-18 & H-19  
SIPCOT Industrial Park  
Vallam Vadagal, Echoor Post  
Sriperumbudur Taluk  
Kancheepuram District  
Tami Nadu - 631 604  
Tel: +91-44-67170100



THE SMART CHOICE FOR FLOW CONTROL SINCE 1986.  
WITH MORE THAN 300 LOCATIONS WORLDWIDE,  
FIND A REPRESENTATIVE NEAR YOU AT **BRAY.COM**

All statements, technical information, and recommendations in this bulletin are for general use only. Consult Bray representatives or factory for the specific requirements and material selection for your intended application. The right to change or modify product design or product without prior notice is reserved. Patents issued and applied for worldwide.