

Tri Lok[®]

Triple Offset Valves

Total Cost of Ownership

Industrial valves are an integral part of many different processes and typically represent a significant financial investment. Therefore, the proper selection of valves for a given application should include both technical and commercial considerations.

Technical considerations are generally well defined so as not to sacrifice or compromise safety or performance, yet from a commercial perspective one consideration that is often overlooked is Total Cost of Ownership.

The question of how to quantify the technical and commercial performance of valves has become more and more important

as end users strive to improve productivity and reduce downtime creating the need for life cycle cost analysis. Life cycle cost analysis has been widely used within the pump industry for many years, but has not been used widely for industrial valves due to the smaller initial investment.

This move from focusing solely on the initial procurement cost to looking at the total cost of ownership can generally result in realizing a greater return on investment over the life of the valve. Some of the factors to consider relative to the total cost of ownership are diagrammed below.

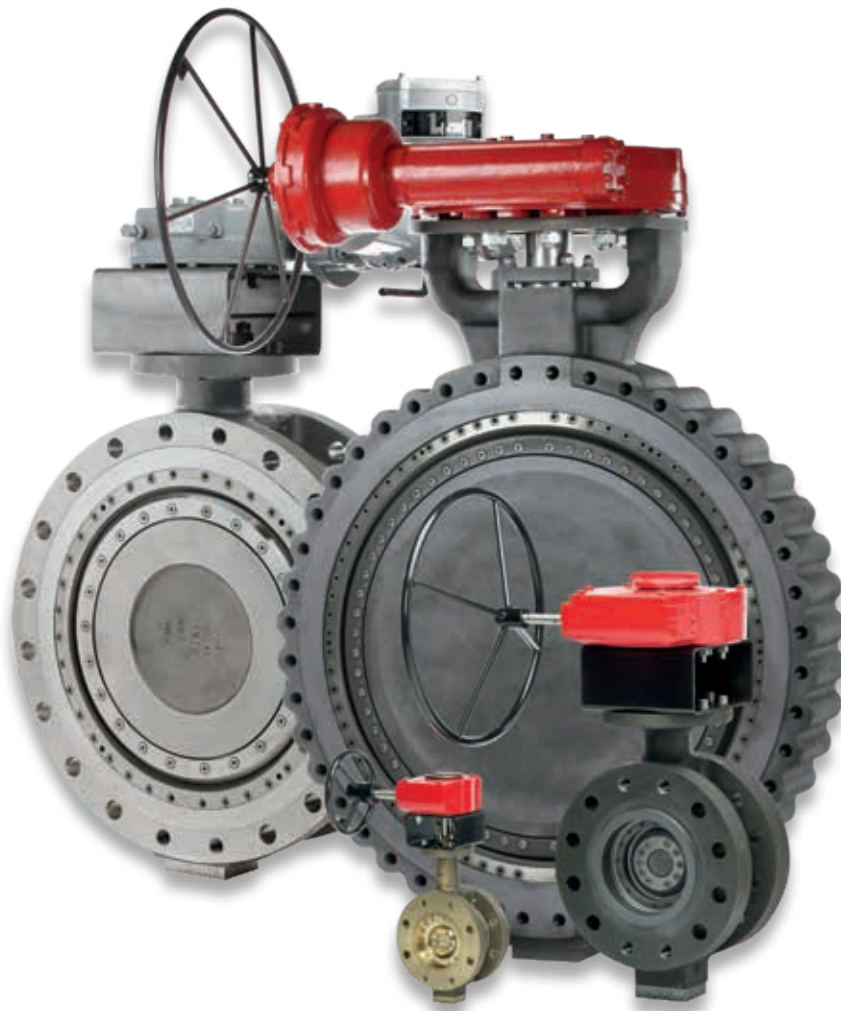

- > 12" ASME Class 600
- > ISO 5752 Double Flange Body
- > Stainless Steel Construction
- > Spring Return Actuator

 **Bray**[®]

THE HIGH PERFORMANCE COMPANY

Tri Lok[®]

Triple Offset Valves

Total Cost of Ownership

The Bray Tri Lok triple offset valve has been designed and developed to maximize performance and reliability while minimizing Total Cost of Ownership. With that in mind Bray has introduced the Tri Lok triple offset valve in sizes 3" – 48" in ASME Class 150 and 300, and 4" – 24" in ASME Class 600.

The standard Bray Tri Lok product range allows for the field replacement of both the seal ring AND the valve seat which offers significant advantages over triple offset valves with integral seats that are welded and machined into the valve body, and are therefore not replaceable.

As well, the standard seat material for the Bray Tri Lok triple offset valve is specially nitride hardened making it considerably more durable and therefore superior in performance and reliability even in harsh critical applications when compared to other products on the market.

This safe, simple, unique design differentiates the Tri Lok product range by providing end-users the ability to repair their valves locally rather than having to send them back to the manufacturer, thus reducing downtime and significantly lowering the total cost of ownership.

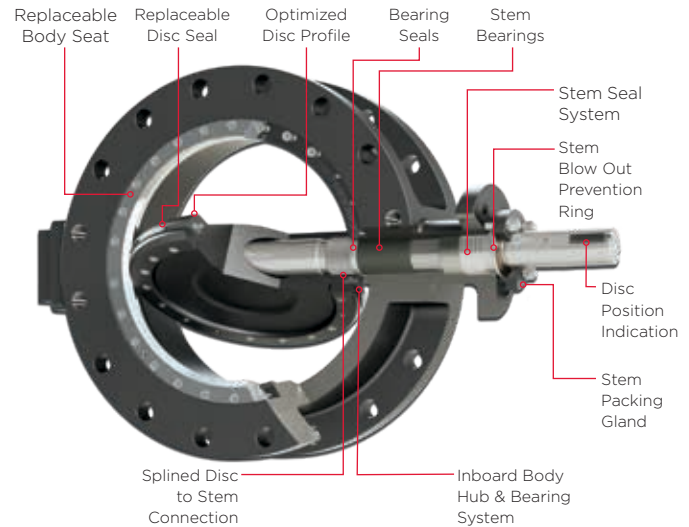

The total cost of ownership of Tri Lok triple offset valves compared with an integral seated triple offset valve is summarized below. This comparison considers ONE OFF of each size. You can calculate your expected total cost of ownership savings by looking at the size and number of valves and adding your "Downtime and Lost Production" costs at your particular location.

Total Cost of Ownership Example

	24" Class 150		Δ %	12" Class 150		Δ %
	Tri Lok	Integral Seat		Tri Lok	Integral Seat	
Initial Cost	\$12,500	\$12,500	0%	\$3,500	\$3,500	0%
Installation Cost ¹	\$1,250	\$1,250	0%	\$350	\$350	0%
Removal Cost ¹	\$1,250	\$1,250	0%	\$350	\$350	0%
Repair Cost ²	\$1,250	N/A		\$350	N/A	
Repair Parts ³	\$2,800	N/A		\$883	N/A	
Replacement Valve Cost	N/A	\$12,500		N/A	\$3,500	
Total Cost of Ownership	\$19,050	\$27,500		\$5,433	\$7,700	
Estimated Savings	\$8,450		31%	\$2,267		29%

Notes:

1 Installation and removal cost assumed at 10% of the initial purchase price

2 Repair cost assumed at 10% of the initial purchase price

3 Repair parts include seat, laminated seal ring, and necessary gaskets required to return the valve to like new condition

Bray [®]

US HEADQUARTERS
Bray International, Inc.
 13333 Westland East Blvd.
 Houston, Texas 77041
 Tel: 281.894.5454
 www.bray.com

All statements, technical information, and recommendations in this bulletin are for general use only. Consult Bray representatives or factory for the specific requirements and material selection for your intended application. The right to change or modify product design or product without prior notice is reserved. Patents issued and applied for worldwide.

Bray[®] is a registered trademark of Bray International, Inc.

© 2020 Bray International, Inc. All rights reserved.

B-1062_EL_Tri Lok Ownership_2020-01