

Bray *SERIES 98*

SCOTCH YOKE ACTUATOR

SIL SAFETY MANUAL

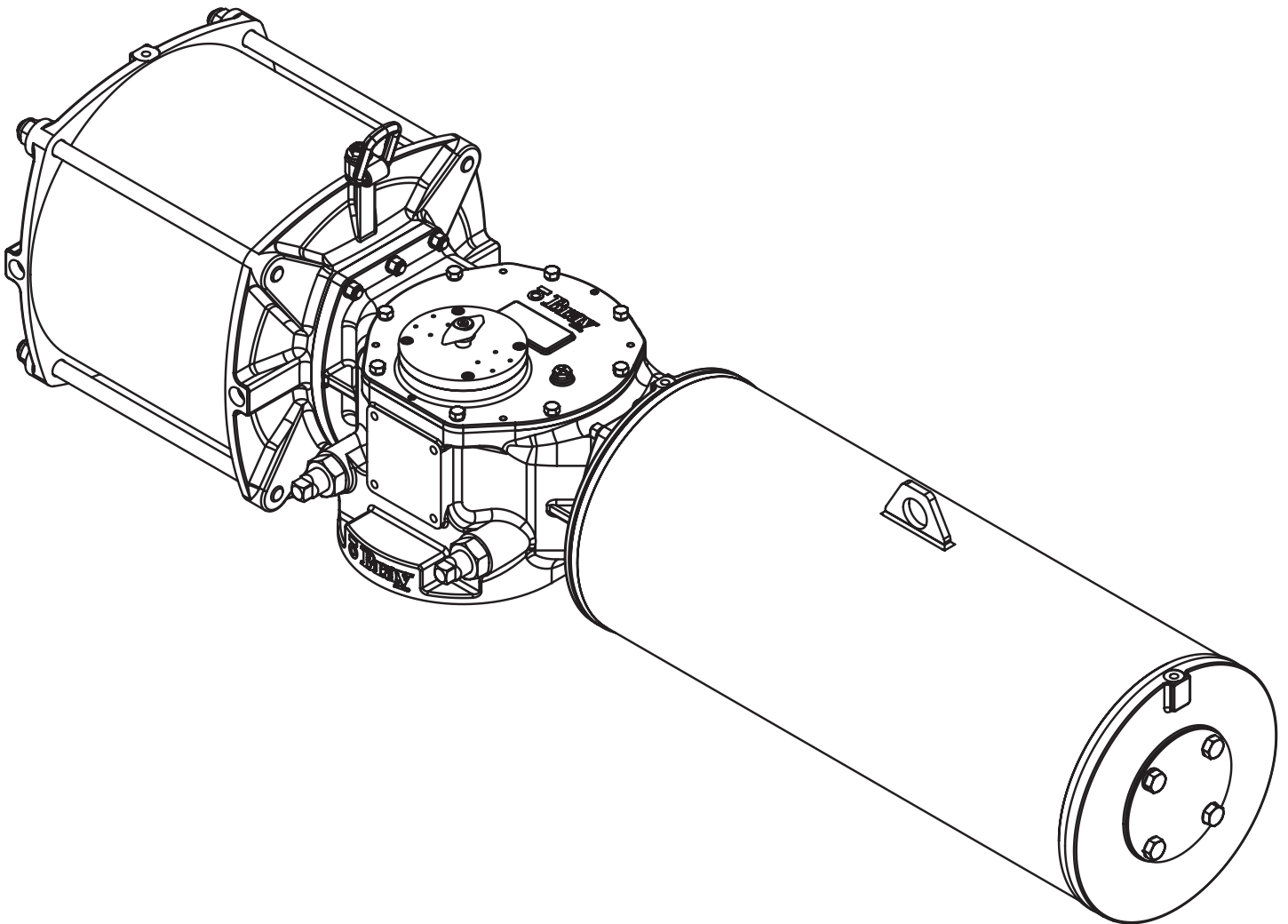

TABLE OF CONTENTS

1.0 Introduction	1
1.1 Terms and Abbreviations	1
1.2 Acronyms	1
1.3 Product Support	2
1.4 Related Literature	2
1.5 Reference Standards	2
2.0 Device Description	2
3.0 Designing a SIF Using a Manufacturer Product	2
3.1 Safety Function	2
3.2 Environmental Limits	2
3.3 Application Limits	2
3.4 Design Verification	3
3.5 SIL Capability	3
3.5.1 Systematic Integrity	3
3.5.2 Random Integrity	3
3.5.3 Safety Parameters	3
3.6 Connection of the S92/93 Pneumatic Actuator to the SIS Logic-Solver	3
3.7 General Requirements	3
4.0 Installation and Commissioning	4
4.1 Installation	4
4.2 Physical Location and Placement	4
4.3 Pneumatic Connections	4
5.0 Operation and Maintenance	5
5.1 Proof Test without Automatic Testing	5
5.2 Proof Test with Automatic Partial Operational Stroke Testing	5
5.3 Repair and Replacement	5
5.4 Useful Life	5
5.5 Manufacturer Notification	6
5.6 Product Registration	6

1.0 Introduction

This Safety Manual provides information necessary to design, install, verify and maintain a Safety Instrumented Function (SIF) using Bray's Series 98 Pneumatic Scotch Yoke Actuator. This manual provides necessary requirements for meeting the IEC 61508 or IEC 61511 functional safety standards.

1.1 Terms and Abbreviations

Safety - Freedom from unacceptable risk of harm.

Functional Safety - The ability of a system to carry out the actions necessary to achieve or to maintain a defined safe state for the equipment / machinery / plant / apparatus under control of the system.

Basic Safety - The equipment must be designed and manufactured such that it protects against risk of damage to persons by electrical shock and other hazards and against resulting fire and explosion. The protection must be effective under all conditions of the nominal operation and under single fault condition.

Safety Assessment - The investigation to arrive at a judgment - based on evidence - of the safety achieved by safety-related systems.

Fail-Safe State:

Spring Return - State where hold position air is released and the spring is extended

Double Acting - State where the hold position pressure is released and pressure is supplied to the trip side of the actuator

Fail Safe - Failure that causes the valve to go to the defined fail-safe state without a demand from the process.

Fail Dangerous - Failure that prevents the actuator from rotating with sufficient torque to move a valve to its fail-safe state.

Fail Dangerous Undetected - Failure that is dangerous and that is not being diagnosed by automatic diagnostics, such as partial valve stroke testing.

Fail Dangerous Detected - Failure that is dangerous but is detected by automatic diagnostics, such as partial valve stroke testing.

Fail No Effect - Failure of a component that is part of the safety function but that has no effect on the safety function.

Low Demand Mode - Where the frequency of demands for operation made on a safety-related system is no greater than twice the proof test frequency.

1.2 Acronyms

FMEDA - Failure Modes, Effects and Diagnostic Analysis.

HFT - Hardware Fault Tolerance.

MOC - Management of Change. These are specific procedures often done when performing any work activities in compliance with government regulatory authorities.

PFDavg - Average Probability of Failure on Demand.

SFF - Safe Failure Fraction, the fraction of the overall failure rate of a device that results in either a safe fault or a diagnosed unsafe fault.

SIF - Safety Instrumented Function, a set of equipment intended to reduce the risk due to a specific hazard (a safety loop).

SIL - Safety Integrity Level, discrete level (one out of a possible four) for specifying the safety integrity requirements of the safety functions to be allocated to the E/E/PE safety-related systems where Safety Integrity Level 4 has the highest level of safety integrity and Safety Integrity Level 1 has the lowest.

SIS - Safety Instrumented System – Implementation of one or more Safety Instrumented Functions. An SIS is composed of any combination of sensor(s), logic solver(s), and final element(s).

1.3 Product Support

Product support can be obtained from:

Bray Controls Inc.
13333 Westland Blvd. East
Houston, TX, 77041, USA.
Phone: 281 894 5454
www.braycontrols.com

1.4 Related Literature

Hardware Documents:

- Series 98 Actuator Installation, Operation and Maintenance Instructions
- Series 98 Brochure
- Series 98 Technical Manual

Guidelines/References:

- Safety Integrity Level Selection – Systematic Methods Including Layer of Protection Analysis, ISBN 1-55617-777-1, ISA
- Control System Safety Evaluation and Reliability, 2nd Edition, ISBN 1-55617-638-8, ISA
- Safety Instrumented Systems Verification, Practical Probabilistic Calculations, ISBN 1-55617-909-9, ISA

1.5 Reference Standards

Functional Safety:

- IEC 61508: 2000 Functional safety of electrical/electronic/ programmable electronic safety-related systems
- IEC 61511 - ANSI/ISA 84.00.01-2004 Functional Safety – Safety Instrumented Systems for the Process Industry Sector
- ISO 5211:2001(E) Industrial Valves- Part Turn actuator attachment.
- IEC 60529 Degrees of protection provided by enclosures (IP Code)
- CEN/TC – Draft
- BS EN 15714-3:2009 Pneumatic Part-turn actuators for industrial valves - Basic requirements

2.0 Device Description

The Series 98 Actuator is a modular design scotch yoke type quarter turn actuator, to actuate various valve types (ball, plug and butterfly styles) or other final

elements such as dampers. The scotch yoke actuator renders torque output suitable to the requirement of these styles of valves, wherein the torque to operate is not constant through the stroke of the actuator. The linear stroke of the pneumatic cylinder is converted to rotary motion of the Yoke, and the torque output that is higher at the ends of stroke and minimum at mid stroke.

It operates with air supply pressure from 40 to 150 psi (2.75 to 10.3 bar) and the fail safe direction is field-reversible. The actuators come in two basic configurations, Double Acting and Spring Return. The modular construction of the Pressure, Torque and the Spring Modules makes the fail safe direction easily reversible. The manual overrides and options with accessories cater to the varied requirements of applications.

3.0 Designing a SIF Using a Series 98 Actuator

3.1 Safety Function

When de-energized, the Actuator moves to its fail-safe position. Depending on configuration of the final element, the Actuator will rotate the valve plug to close off the flow path through the valve body or open the flow path through the valve body. When using a double acting actuator as part of a SIF the availability of the air supply must be included in the reliability analysis.

The Series 98 Actuator is intended to be part of final element subsystem as defined per IEC 61508 and the achieved SIL level of the designed function must be verified by the designer.

3.2 Environmental limits

The designer of a SIF must check that the product is rated for use within the expected environmental limits. Refer to the Series 98 Technical Manual for environmental limits.

3.3 Application limits

The materials of construction of the actuator are specified in the Series 98 Actuators Brochure and Technical Manual. It is especially important that the designer check for material compatibility considering

on-site chemical contaminants and air supply conditions. If the Actuator is used outside of the application limits or with incompatible materials, the reliability data provided becomes invalid.

3.4 Design Verification

A detailed Failure Mode, Effects, and Diagnostics Analysis (FMEDA) report is available from Bray. This report details all failure rates and failure modes as well as the expected lifetime.

The achieved Safety Integrity Level (SIL) of an entire Safety Instrumented Function (SIF) design must be verified by the designer via a calculation of PFD_{AVG} considering architecture, proof test interval, proof test effectiveness, any automatic diagnostics, average repair time and the specific failure rates of all products included in the SIF. Each subsystem must be checked to assure compliance with minimum hardware fault tolerance (HFT) requirements. The exida exSILentia® tool is recommended for this purpose as it contains accurate models for the actuator and its failure rates.

When using a Series 98 actuator in a redundant configuration, a common cause factor of 10% should be included in safety integrity calculations unless a lower value can be justified based on site conditions.

The failure rate data listed in the FMEDA report is only valid for the useful life time of the actuator. The failure rates will increase sometime after this time period. Reliability calculations based on the data listed in the FMEDA report for mission times beyond the lifetime may yield results that are too optimistic, i.e. the calculated Safety Integrity Level will not be achieved.

3.5 SIL Capability

3.5.1 Systematic Integrity

The product has met manufacturer design process requirements of Safety Integrity Level (SIL) 3. These are intended to achieve sufficient integrity against systematic errors of design by the manufacturer. A Safety Instrumented Function (SIF) designed with this product must not be used at a SIL level higher than the statement without “prior use” justification by end user or diverse technology redundancy in the design.



3.5.2 Random Integrity

The Series 98 Actuator is a Type A Device. This Actuator is only one component in the final element. The PFD_{AVG} and SFF must be calculated for the entire final element subsystem. This analysis must account for any hardware fault tolerance and architecture constraints.

3.5.3 Safety Parameters

For detailed failure rate information refer to the Failure Modes, Effects and Diagnostic Analysis Report for the Series 98 Actuator.

3.6 Connection of the Series 98 Actuator to the SIS Logic-solver

The Series 98 Actuator is connected to the safety rated logic solver through a control device such as a solenoid or valve positioner.

3.7 General Requirements

The system’s response time shall be less than process safety time as defined in the SIF Safety Requirements Specification. Since the response time of the Series 98 Actuator depends upon the line size, tubing, line pressure, flow constrictors like flow control valves, Cv of the control elements like solenoid valves, their response times, pressure regulators, quick exhaust valves, hydraulic override (on DA models), sandwich gearbox manual override, the response time must be confirmed for each final element assembly. All SIS components including the Series 98 Actuator must be operational before process start-up.

The user shall verify that the Series 98 Actuator is suitable for use in safety applications by confirming the actuator’s nameplate is properly marked.

Personnel performing maintenance and testing on the Series 98 Actuator shall be competent to do so.

Results from the proof tests shall be recorded and reviewed periodically.

The useful life of the Actuator is discussed in the Failure Modes, Effects and Diagnostic Analysis Report for the Series 98 Actuator

4.0 Installation And Commissioning

4.1 Installation

The Series 98 Actuator must be installed per standard practices outlined in the Installation Manual.

The environment must be checked to verify that environmental conditions do not exceed the ratings.

The Actuator must be accessible for physical inspection.

4.2 Physical Location and Placement

The Series 98 Actuator shall be accessible with sufficient room for pneumatic connections and shall allow manual proof testing.

Pneumatic piping to the valve shall be kept as short and straight as possible to minimize the airflow restrictions and potential clogging. Long or kinked pneumatic tubes may also increase the valve closure time.

The Actuator shall be mounted in a low vibration environment. If excessive vibration can be expected special precautions shall be taken to ensure the integrity of pneumatic connectors or the vibration should be reduced using appropriate damping mounts.

4.3 Pneumatic Connections

Recommended piping for the pneumatic connections to the Actuator is the same as the nominal port size for the stainless steel or PVC tubing. The length of tubing between the Series 98 Actuator and the control device, such as a solenoid valve, shall be kept as short as possible and free of kinks.

Only dry instrument air filtered to 40 micron level or better shall be used.

The process air pressure shall meet the requirements set forth in the installation manual.

The process air capacity shall be sufficient to move the valve/ final element within the required time.

5.0 Operation And Maintenance

5.1 Proof test without automatic testing

The objective of proof testing is to detect failures within the Actuator that are not detected by any automatic diagnostics of the system. Of main concern are undetected failures that prevent the safety instrumented function from performing its intended function.

The frequency of proof testing, or the proof test interval, is to be determined in reliability calculations for the safety instrumented functions for which a Series 98

Actuator is applied. The proof tests must be performed more frequently than or as frequently as specified in the calculation in order to maintain the required safety integrity of the safety instrumented function.

The following proof test is recommended. The results of the proof test should be recorded and any failures that are detected and that compromise functional safety should be reported to Bray Controls. The suggested proof test consists of a full stroke of the valve coupled to the Series 98 Actuator.

Table 1: Recommended Proof Test

Step	Action
1	Bypass the safety function and take appropriate action to avoid a false trip.
2	Interrupt or change the air supply to the actuator to force the actuator and valve to the Fail-Safe state and confirm that the Safe State was achieved and within the correct time.
3	Restore air supply to the actuator and inspect the actuator for any leaks, visible damage or contamination and confirm that the normal operating state was achieved.
4	Remove the bypass and otherwise restore normal operation.
5	Restore normal operation.

Table 3 lists the proof test coverage for various product configurations

Table 2: Proof Test Coverage

Device	Normal	With PVST
Series 98, Spring-Return Actuator, SR	92%	78%
Series 98, Double Acting Actuator, DA	92%	76%
Series 98, Double Acting Actuator, DD	92%	76%

The person(s) performing the proof test of a Series 98 Actuator should be trained in SIS operations, including bypass procedures, valve maintenance and company Management of Change procedures. No special tools are required.

5.2 Proof test with automatic partial operational stroke testing

An automatic partial valve stroke testing scheme that performs a partial full stroke of the isolation valves with the Series 98 Actuator and measures valve movement and timing will detect many potentially dangerous failure modes. It is recommended that a physical inspection (Step 3 from Table 1) be

performed on a periodic basis with the time interval determined by plant conditions. A maximum inspection interval of five years is recommended.

5.3 Repair and replacement

Repair procedures in the Series 98 Actuator Installation, Operation and Maintenance manual must be followed.

5.4 Useful Life

The useful lives of specific components in the assembly are listed in Table 3 (Page 6) and the nominal cycles between maintenance is listed in Table 4 (Page 6).

Table 3: Useful Life of Components

Component	Useful Life
Seals	3 years

Table 4: Cycles Between Maintenance

Nominal Torque (Nm)	Cycle Life
≤ 125	500,000
≤ 1,000	500,000
≤ 2,000	250,000
≤ 8,000	100,000
≤ 32,000	25,000
≤ 63,000	10,000
≤ 125,000	5,000
≤ 250,000	2,500

Based on general field failure data a product life period of approximately 30 years is expected for the Series 98 Actuator if the lower level components are renewed before the end of their useful life and the device is maintained per manufacturer’s instructions. When plant experience indicates a shorter useful lifetime than indicated in this appendix, the number based on plant experience should be used.

5.5 Manufacturer Notification

Any failures that are detected and that compromise functional safety should be reported to Bray Controls. In case of failure please refer to the back cover and contact your regional Bray customer service.

5.6 Product Registration: If the product is being used in a safety application and there is a desire to receive notices regarding the product, register the product with Bray Controls customer service.



Bray CONTROLS

A Division of BRAY INTERNATIONAL, Inc.
13333 Westland East Blvd. Houston, Texas 77041
281/894-5454 FAX 281/894-9499 www.bray.com

Bray® is a registered trademark of BRAY INTERNATIONAL, Inc.
© 2010 Bray International. All rights reserved. SM-1005_S98_2020-06