SERIES 76
ELECTRIC ACTUATORS
TECHNICAL SALES MANUAL



OVERVIEW	3
FEATURES & BENEFITS	4
PART NUMBERING	6
CERTIFICATIONS & DIRECTIVES	7
OPTIONS	9
ELECTRICAL DATA	10
GENERAL DETAILS	19
WEATHERPROOF DIMENSIONS SIZES 1 - 4	20
WEATHERPROOF DIMENSIONS WITH LCS SIZES 1 - 4	21
WEATHERPROOF DIMENSIONS SIZE 5	22
WEATHERPROOF DIMENSIONS WITH LCS SIZE 5	23
WEATHERPROOF DIMENSIONS SIZE 6	24
WEATHERPROOF DIMENSIONS WITH LCS SIZE 6	25
WEATHERPROOF DIMENSIONS SIZE 7	26
WEATHERPROOF DIMENSIONS WITH LCS SIZE 7	27
EXPLOSIONPROOF DIMENSIONS SIZES 1 - 4	28
EXPLOSIONPROOF DIMENSIONS WITH LCS SIZES 1 - 4	29
EXPLOSIONPROOF DIMENSIONS SIZE 5	30
EXPLOSIONPROOF DIMENSIONS LCS SIZE 5	31
BUSHING MACHINING OPTIONS	32
ACTUATOR DRAWING REFERENCE	33

OVERVIEW



High performance without compromise. The Series 76 is a heavy-duty, quarter turn electric actuator ideal for industrial valve automation. Available in various power voltage supplies and designed for on/off and modulating applications for a wide range of markets and industries.

The Bray series 76 is a quarter-turn industrial electric actuator with manual override for use on any quarterturn valve or damper requiring up to 79k in-lbs (9,000 Nm) of torque. Operating speeds vary between 17 to 130 seconds depending on torque, voltage, and frequency.

KEY FEATURES

- > Torque up to 79,000 in-lbs (9,000 Nm)
- > 3-Phase, 1-Phase, & DC Power
- > Special High torque induction motor with built in thermal protection to protect against overheating
- > Direct mounts to most quarter turn valves according to EN ISO 5211, resulting in a lower profile
- > Continuous valve position indication even on loss power
- > Padlockable declutch system for manual operation
- > Integral control station options
- > Removable blank bushing for ease of machining
- > Self-locking worm gear design eliminating the need for a motor brake
- > 4 Limit Switches standard on most sizes
 - Additional auxiliary limit switches available
- > Torque switches standard in actuator size 2 and above
- > Anti condensation heater
- > Permanently lubricated
- > Up to 28 point terminal strip

APPLICATIONS

On/Off
Modulating Control

PERFORMANCE

Output Torque	See Torque Chart
Voltages	See Motor Chart
Ambient Temperature	-4°F -20°C to 140°F +60°C -40°F -40°C to 140°F +60°C Opt.
On/Off Applications	Per EN 22153 Class A
Modulating Applications	Per EN 22153 Class C

SPECIFICATIONS

Voltage	> 3 Phase: 220V, 380V & 460V > 1 Phase: 110V, 220V & 240V AC > 24V DC, 24V AC/DC
Torque rating	> 3 Phase: Torque up to 79,000 in-lbs (9,000 Nm) > 1 Phase: Torque up to 26,500 in-lbs (3,000 Nm)
Certifications	Weatherproof: FCC, ICES, CE, UKCA, CSA Explosionproof: FCC, ICES, ATEX, IECEx, CSA
Enclosure Ratings	> NEMA: 4, 4X, 6 > Ingress Protection: IP66/67 > Submersible: IP68 (Optional)
Main Housing	> High grade aluminum alloy > Anodized interior and exterior > Polyester powder top coated
Position Indicator	Top mount visual position indicator
Travel	90 degrees +/- 5°
Motor	Squirrel Caged AC Induction Motor > Class F Motor Insulation 311F (155C) > Embedded thermal protection 275F (135C) DC Brushed Motor > Class B Motor Insulation 266F (130C)
Duty Cycle	S4 Per EN 60034-1
Control Options	> Potentiometer: 1K Ohm > Position Transmitter: Output Signal: 4-20mA dc > Modulating: 0-20mA, 4-20mA, 0-5V, 1-5V, 0-10V, 2-10V > Local Control Stations
Conduit Entries	Weatherproof: Sizes 1 thru 5 = 3x 3/4" NPT or 3x M20 Sizes 6 thru 7 = 2x 3/4" NPT + 1x 1" NPT or 2x M20 + 1x M25 Explosionproof: 2x 3/4" NPT or 2x M25
Drive Bushing	Removable Drive Bushing
Mounting	ISO 5211/MSS SP-101
Lubrication	Grease moly EP type
Manual Override	Declutch Mechanism, which can be padlocked.

FEATURES & BENEFITS

FEATURES

1 High Visibility Position Indicator: The display indicates valve position through the full range of travel. The O-ring sealed dome is made of high impact, heat, chemical and ultraviolet resistant clear polycarbonate and designed to withstand caustic wash down ensuring excellent corrosion protection.

Weatherproof: Sizes 1 through 4 and size 6 have top mount dome, prominently labeled and color coded yellow for open, red for close. **See Fig. 1.**

Sizes 5 and 7 using an auxiliary gearbox will have a clear dome with green markings indicate open while red indicates closed. **See Fig. 2.**

Explosionproof: Sizes 1 through 5 uses flat indicator window dial. **See Fig 3.**

2 Enclosure: The housing is fully anodized internally and externally, with a polyester powder topcoat applied to ensure corrosion, wear, and UV resistance in the harshest environments.

3 Captive Cover Bolts: The cover is attached to the base by captive stainless-steel bolts placed outside the sealing area.

4 O-ring Seal: The o-ring between the cover and base provides environmental sealing preventing internal corrosion.

5 Manual Override: Hand-operated declutch lever physically disconnects the motor drive from the handwheel for manual operation. The lockable lever prevents any unauthorized operation.

6 Mechanical Travel Stops: Designed to prevent over-travel in the open or close direction during manual operation. Travel stops bolts include a locknut to prevent loosening, and seals to prevent water ingress.

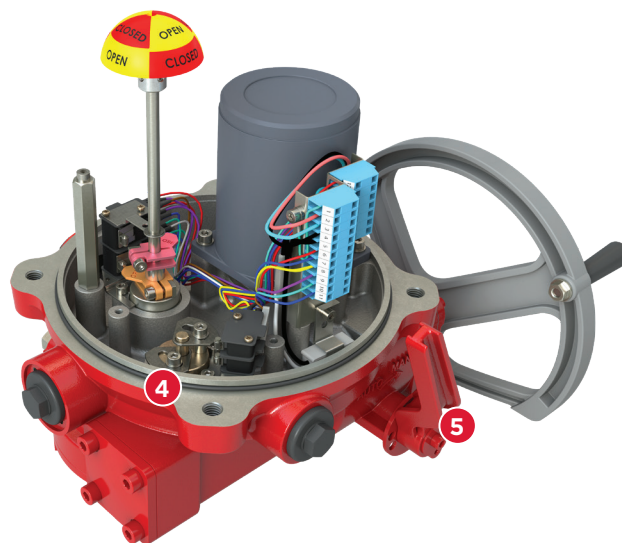
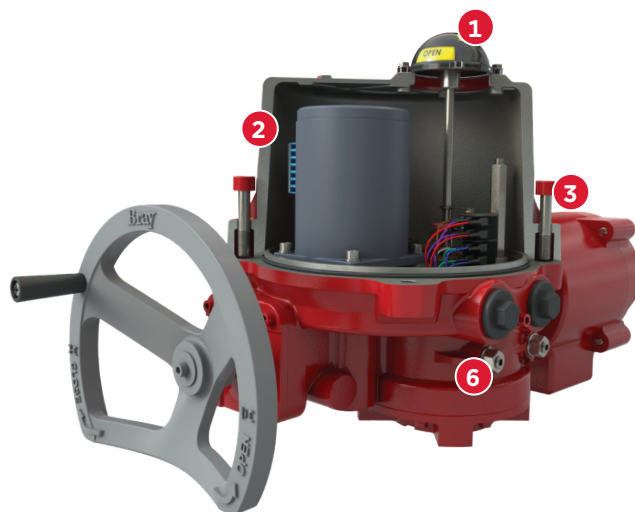

Figure 1: Sizes 1-4, and Size 6.

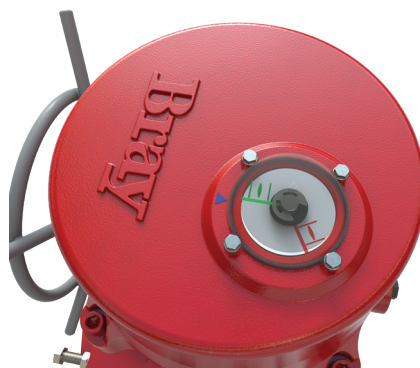

Figure 2: Sizes 5 & 7.

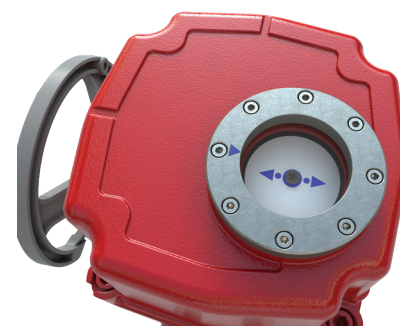
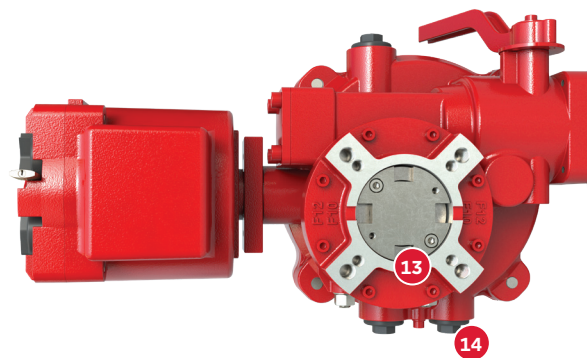
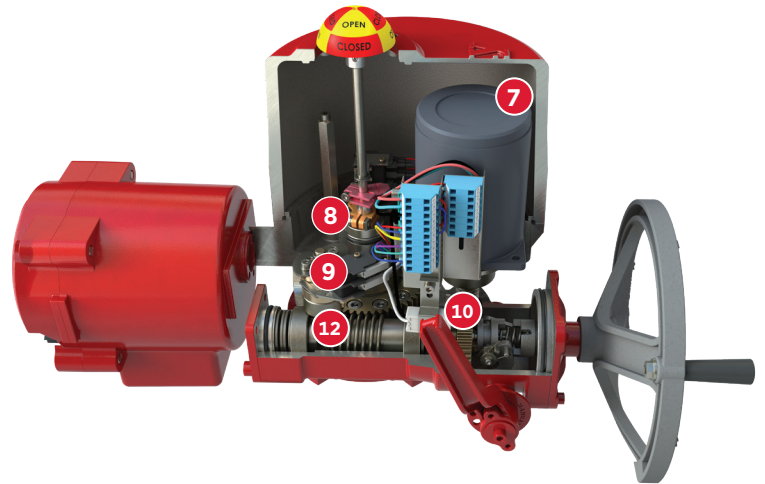

Figure 3: Sizes 1-5.

FEATURES & BENEFITS

FEATURES

- 7 Motor:** Fan cooled, high torque, squirrel Caged AC Induction Motor with Class F insulation or DC brushed motor with Class B insulation.
- 8 Limit Switches:** Rotary switch type for easy configuration. 4 limit switches standard.
 - > 2 Available for position feedback.
 - > Additional limit switches available
- 9 Torque Switches:** Open and close torque switches protect the valve for actuator sizes 2 and above. Switches are set at unit rating to eliminate nuisance tripping.
- 10 Heater:** Thermostatically controlled to combat condensation build-up in the unit.
- 11 Local Control Station:** Integral to actuator housing. Local-Remote-Stop padlockable selector, Open-close selector, Power (white), Open/ Opening (Red), Remote (Blue), Close/Closing (Green) and Fault (Yellow) LED lights. Available as an option for 1 Phase and standard in 3 phase.
- 12 Output Drive:** Double reduction worm gear design allows output motor torque to be transmitted to the valve. The design incorporates a self-locking feature preventing external forces adversely effecting desired valve position and equipped with anti-rotation mechanism.
 - > Worm: Alloy Steel
 - > Worm Gear: Bronze
- 13 Mounting:** Optional flange sizes for easy installation to any valve type and size per ISO 5211
- 14 Conduit Entries:** Incoming power and control cable connections. Standard protective plastic covers.



PART NUMBERING SYSTEM

Select one code from each category to build a complete actuator order number.

PN	76	2	A	0	0	-	113	0	0	0	0	0	A	2	Blank
Field	I	II.a	II.b	III	IV	-	V	VI	VII	VIII	IX	X	XI.a	XI.b	XII

I	II.a	II.b		III	IV		V	VI				
Series	Act. Size	Type		Torque Per Size	Enclosure Rating		Conduit & Mounting	-	Actuator	Voltage		
76	1	A	Weatherproof	Low	0	WP - IP66/67	0	Imperial	-	113	0	110V AC - 1 Phase
	2	B	Weatherproof	Medium	2	WP - IP66/67/68	5	Metric			2	220V AC - 1 Phase
	3	C	Weatherproof	High	3	XP - cCSAus					3	220V AC - 3 Phase
	4	X	Explosionproof	Low	4	XP - ATEX/IECEX					4	380V AC - 3 Phase
	5	Y	Explosionproof	Medium							6	460V AC - 3 Phase
	6	Z	Explosionproof	High							7	24V DC
	7										8	24V AC/DC
											9	240V AC - 1 Phase

VII	VIII	IX	
Controller type	Control Station Options	Coating	Temp Rating
0 On/Off Control	0 No External Device	0 Red PPC	-4°F/-20°C to 140°F/+60°C
2 Modulating Analog Control	C Local Control Station	A Red PPC	Low Temp: Consult Factory
3 On/Off with Position Transmitter			
4 On/Off with Potentiometer			

XI.a	XI.a	Valve Mounting Codes ³						XI.b	XII
Switch Options	Bushing Material	Actuator Sizes (Field II.a)							Special Options
0 2 Limit Switches (Size 1 Only)	A S45C Carbon Steel	1	2	3	4	5	6	7	Blank
0 4 Limit Switches + 2 Torque Switches ²	B 304 Stainless Steel	Blank Bushing (Not machined)						Blank	/TBD
2 2 Addt'l. Auxiliary limit switches (ALS) ¹	C 316 Stainless Steel	A	B	C ⁴	E	F ⁴	G	G ⁴	1
3 2 Addt'l. Auxiliary Torque Switches (ATS) ²		B	C	D	F	G	H ⁴	H ⁴	2
4 2 Addt'l. Aux. LS (ALS) & 2 Addt'l. Aux. TS (ATS) ²		C		E				F25-2	3
		Customized Bushing: Add XII						C	

NOTES:

1. Size 1X & 1Y (Explosionproof), Additional auxiliary (ALS) are not available with modulating control card option.
2. Not available in sizes 1A/1X & 1B/1Y.
3. Please refer to page 33 for machined bushing option details.
4. Indicates bracket and adaptor required.
5. For combination of available options please consult factory.
6. All units come with space heater.

PART NUMBER EXAMPLE: 762A00-11300000/A2

76	Series 76 Industrial Electric Actuator, Quarter Turn
2A	Actuator Model 2A, Torque Rating 1330 in-lbs (150 Nm.)
0	Weatherproof IP66/67
0	Imperial
-113	Actuator
0	110V AC-1 PH
0	On/Off Control
0	No External Device
0	Red Polyester Powder Coating and -4°F/-20°C to 140°F/60°C Ambient Temperature
0	4 Limit Switches + 4 Torque Switches + 2 Aux. LS
/A2	S45 Carbon Steel Bushing, factory machined to valve mounting Code C

WEATHERPROOF

Actuator Model	AC/DC	Single Phase			3 Phase		
	24V	110V	220V	240V	380V	460V	220V
1A							
1B							
2A							
2B							
3A							
3B							
3C							
4A							
4B							
5A							
5B							
6A							
6B							
7A							
7B							
7C							

EXPLOSIONPROOF

Actuator Model	AC/DC	Single Phase			3 Phase		
	24V	110V	220V	240V	380V	460V	220V
1X							
1Y							
2X							
2Y							
3X							
3Y							
3Z							
4X							
4Y							
5X							
5Y							

CSA > C22.2 No.139
> UL 429

CE & UKCA > Low Voltage Directive
> EMC Directive
> Machinery Directive
> RoHS/ REACH

Environmental > NEMA 4/4X/6
> IP66/67 (IP68 optional)

Others > FCC/ICES

NOTE

	CSA, CE, & UKCA
	CE & UKCA

ATEX/IECEX > II 2G Ex db IIB T4 Gb
> II 2D Ex tb IIIC T135°C Db

CE > ATEX Directive
> Low Voltage Directive
> EMC Directive
> Machinery Directive
> RoHS/ REACH

CSA **Canadian Hazardous Locations**
> Class I, Div 1, Groups C, D; T4
> Ex d IIB T4 Gb
USA Hazardous Locations
> Class I, Div 1, Groups C, D; T4
> Class I, Zone 1, AEx d IIB T4 Gb
Canadian and USA Safety
> C22.2 No.139
> UL 429

Environmental > NEMA 4/4X/6
> IP66/67

NOTE

	CSA, IECEX, & ATEX
	IECEX & ATEX

OPTIONS

AUXILIARY LIMIT SWITCHES

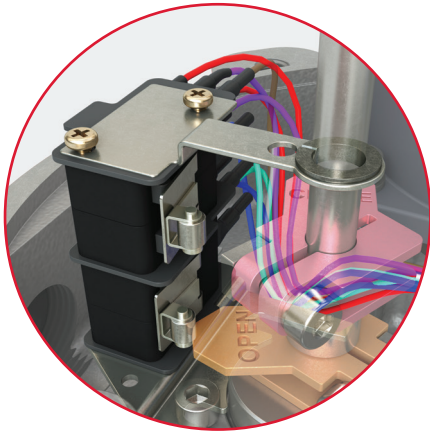

In addition to the limit switches used to control the 'open' and 'closed' travel limits, actuators sized 2 through 7 have two auxiliary switches installed as part of the standard configuration. These auxiliary switches are assembled so that they are activated 3 degrees before their associated limit switch. Actuators are available with an additional set of auxiliary switches.

AUXILIARY TORQUE SWITCH

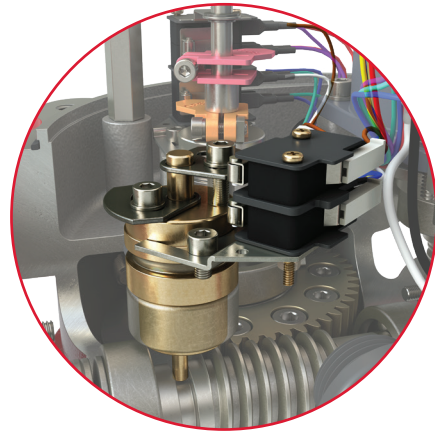

Mechanical Torque switches are a standard factory-installed and calibrated feature for series 76 actuators, sizes 2 through 7. Torque switches are not able to be installed in the size 1. Installation is simple, but due to the requirement for special calibration equipment, it is not available for field installation. Actuators, size 2 through 7, are available with an additional set of torque switches.

POTENTIOMETER

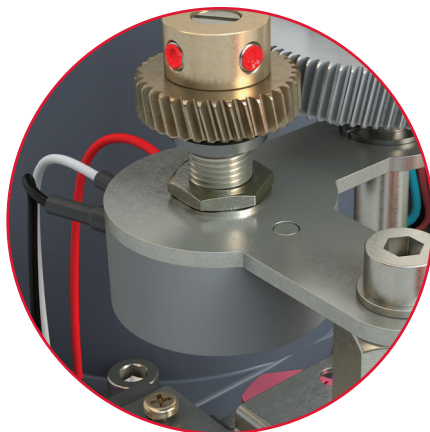

A 1k Ohm potentiometer, standard in modulating applications, is available in on/off applications for direct feedback of position. The potentiometer is factory-calibrated for precise position feedback.

POSITION TRANSMITTER

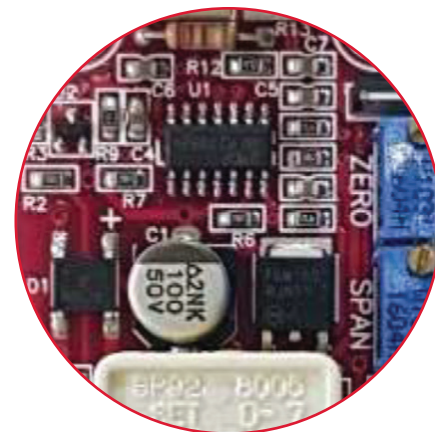

An analog position transmitter is an available option for on/off applications in 1-phase and 3-phase models. The analog transmitter uses a potentiometer to provide continuous valve feedback of a 4-20 mA output signal with accuracy down to +/- 0.5%.

AC & DC MODULATING CONTROL CARDS

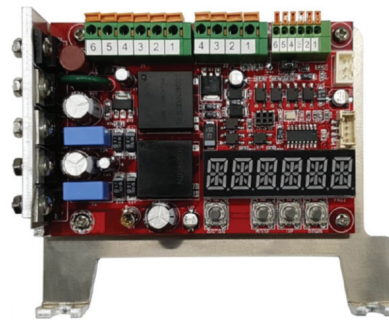
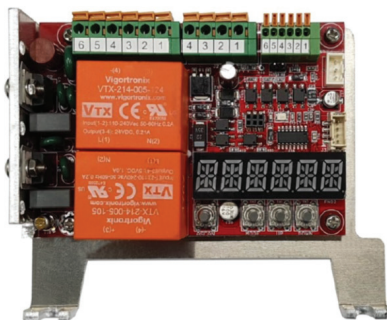

The Series 76 offers precise modulating service for accurate position control.

- > One touch automatic calibration
- > Advanced control of proportional band and dead band
- > Self diagnostics
- > Action on loss of command signal
- > Go to position commands

LOCAL CONTROL STATION (LCS)

The LCS (Local Control Station) offers comprehensive control and monitoring capabilities tailored for the Bray Series 76 Electric Actuator for On/Off and Modulating applications. The LCS is equipped with a local, remote, and stop selector switch and a spring return open, close drive switch.

Enhancing operational awareness and facilitating efficient maintenance, the LCS is outfitted with LED indication to display the valve’s open and close positions, the selection mode (local or remote), power status, and fault indication.



Specifications	Modulating Control Card	LCS Modulating Control Card
Supplying Electric Power	1Ph - AC 110V, 220V, 240V, 50Hz/60Hz 24V DC	3Ph - AC 220V, 380V, 460V, 50Hz/60Hz 1Ph - AC 110V, 220V, 50Hz/60Hz 24V DC, 24V AC/DC
Input Signal	Configurable 0-20 mA, 4-20 mA, 0-10, 2-10, 0-5, 1-5V DC	Configurable 0-20 mA, 4-20 mA, 0-10, 2-10, 0-5, 1-5V DC
Output Signal	Configurable 0-20 mA, 4-20 mA, 0-10, 2-10, 0-5, 1-5V DC	Configurable 0-20 mA, 4-20 mA, 0-10, 2-10, 0-5, 1-5V DC
Fault Position (Loss of Input Signal)	Configurable Close, Open, Last	Configurable Close, Open, Last
Reverse Acting	Configurable Normal Operation Input/Output Reversed Independently	Configurable Normal Operation Input/Output Reversed
Calibration	Configurable Input and Output Signal Adjustment Settings Auto Calibration sequence for travel limits	Configurable Input and Output Signal Adjustment Settings Auto Calibration sequence for travel limits
Dead Band	Configurable 0.3 - 10.0 %	Configurable 0.4 - 7.5%

WEATHERPROOF - CSA, CE, & UKCA

24V AC/DC Power - On/Off

Base Part Number	On/Off Output Torque		On/Off Duty Cycle	Cycles per Hour	Operating Speed	Full Load Current (FLA)	Locked Rotor Current (LRA)	Motor Power
	In-Lbs.	Nm	S4%	Cycles	Sec	Amps	Amps	Watts
761A00-11380000/A	620	70	30	330	18	6.5	12.8	40
761B00-11380000/A	700	80	30	310	19	6.3	12.8	
762A00-11380000/A	1,330	150	40	230	19	6.0	16.9	
762B00-11380000/A	1,410	160	40	180	25	8.5	16.9	
763A00-11380000/A	2,120	240	35	170	29	8.9	30.8	

24V DC Power- Modulating

Base Part Number	Modulating Output Torque		Modulating Duty Cycle	Starts per Hour	Operating Speed	Full Load Current (FLA)	Locked Rotor Current (LRA)	Motor Power
	In-Lbs.	Nm	S4%	Starts	Sec	Amps	Amps	Watts
761A00-11372000/A	530	60	30	720	18	6.5	12.8	40
761B00-11372000/A	600	68	30	720	19	6.3	12.8	
762A00-11372000/A	1,150	130	30	720	19	6.0	16.9	
762B00-11372000/A	1,200	135	30	720	25	8.5	16.9	
763A00-11372000/A	1,750	200	40	960	29	8.9	30.8	

NOTES

1. Full load current (FLA) @ Max. rated load
2. Locked rotor current (LRA) @ Locked rotor load
3. Allowable motor voltage tolerance: +/- 10%
4. Allowable power frequency tolerance: +/- 5%
5. Duty cycle per IEC 60034-1 for on/off and modulating service
6. Starts and cycles per hour based on rated torque

WEATHERPROOF - CSA, CE, & UKCA

110V - Single Phase Power

Base Part Number	On/Off Output Torque		On/Off Duty Cycle	Cycles Per Hour	Modulating Output Torque		Modulating Duty Cycle	Starts Per Hour	Operating Speed (sec)		Full Load Current (FLA) [A]		Locked Rotor Current (LRA) [A]		Motor Power Watts
	In-Lbs.	Nm			S4%	Cycles			In-Lbs.	Nm	S4%	Starts	60 Hz	50 Hz	
761A00-11300000/A	700	80	40	220	580	65	40	960	17	20	1.2	1.1	1.4	1.3	15
761B00-11300000/A	880	100	40	190	620	70	40	960	19	23	1.3	1.2	1.4	1.3	
762A00-11300000/A	1,330	150	50	170	1,150	130	40	960	18	21	2.3	2.3	2.5	2.4	40
762B00-11300000/A	1,750	200	35	170	1,330	150	40	960	25	30	2.3	2.3	2.5	2.4	
763A00-11300000/A	2,650	300	50	110	1,950	220	40	960	25	31	2.6	2.5	2.9	3.0	90
763B00-11300000/A	4,400	500	30	180	3,350	380	40	960	26	32	4.8	4.6	5.0	4.9	
763C00-11300000/A	4,800	550	30	150	3,540	400	40	960	33	39	4.8	4.6	5.0	4.9	180
764A00-11300000/A	6,650	750	25	200	6,020	680	35	840	30	36	6.5	6.5	7.3	7.4	
764B00-11300000/A	9,700	1,100	25	160	8,230	930	35	840	36	43	6.8	6.8	7.3	7.4	
765A00-11300000/A	17,700	2,000	25	60	15,000	1,700	35	840	88	106	6.8	6.8	7.4	7.4	
765B00-11300000/A	26,500	3,000	25	50	22,550	2,550	35	840	108	130	7.0	7.0	7.3	7.4	

220V - Single Phase Power

Base Part Number	On/Off Output Torque		On/Off Duty Cycle	Cycles Per Hour	Modulating Output Torque		Modulating Duty Cycle	Starts Per Hour	Operating Speed (sec)		Full Load Current (FLA) [A]		Locked Rotor Current (LRA) [A]		Motor Power Watts
	In-Lbs.	Nm			S4%	Cycles			In-Lbs.	Nm	S4%	Starts	60 Hz	50 Hz	
761A00-11320000/A	700	80	40	220	580	65	40	960	17	20	0.7	0.7	0.7	0.7	15
761B00-11320000/A	880	100	40	190	620	70	40	960	19	23	0.7	0.7	0.7	0.7	
762A00-11320000/A	1,330	150	35	20	1,150	130	40	960	18	21	1.0	1.0	1.2	1.1	40
762B00-11320000/A	1,750	200	35	170	1,330	150	40	960	24	29	1.1	1.1	1.2	1.1	
763A00-11320000/A	2,650	300	40	150	1,950	220	40	960	24	29	1.3	1.3	1.4	1.5	90
763B00-11320000/A	4,400	500	30	180	3,350	380	40	960	26	32	2.2	2.1	2.4	2.5	
763C00-11320000/A	4,800	550	25	210	3,540	400	40	960	28	34	2.2	2.1	2.4	2.5	180
764A00-11320000/A	6,650	750	25	210	6,020	680	35	840	27	33	3.2	3.0	3.8	3.9	
764B00-11320000/A	9,700	1,100	25	10	7,080	800	35	840	36	43	3.6	3.5	3.9	3.6	
765A00-11320000/A	17,700	2,000	25	60	15,000	1,700	35	840	88	106	3.3	3.2	3.8	3.9	700
765B00-11320000/A	26,500	3,000	25	50	22,550	2,550	35	840	108	130	3.5	3.5	3.8	3.9	
766A00-11320000/A*	31,000	3,500	40	110	30,975	3,500	40	960	33	39	11.2	11.2	17.0	17.0	700
766B00-11320000/A*	35,400	4,000	40	70	35,400	4,000	40	960	49	58	11.2	11.2	17.0	17.0	
767A00-11320000/A*	53,100	6,000	40	50	53,100	6,000	40	960	66	78	9.0	9.0	17.0	17.0	700
767B00-11320000/A*	70,800	8,000	40	30	70,800	8,000	40	960	98	116	9.0	9.0	17.0	17.0	
767C00-11320000/A*	79,700	9,000	40	30	79,650	9,000	40	960	99	117	9.0	9.0	17.0	17.0	

* Sizes 6 and 7 are not CSA Certified

NOTES

1. Full load current (FLA) @ Max. rated load
2. Locked rotor current (LRA) @ Locked rotor load
3. Allowable motor voltage tolerance: +/- 10%
4. Allowable power frequency tolerance: +/- 5%
5. Duty cycle per IEC 60034-1 for on/off and modulating service
6. Starts and cycles per hour based on rated torque

WEATHERPROOF - CE & UKCA

240V - Single Phase Power

Base Part Number	Output Torque		Duty Cycle	Cycles per Hour	Starts per Hour	Operating Speed (sec)		Full Load Current (FLA) [A]		Locked Rotor Current (LRA) [A]		Motor Power
	In-Lbs.	Nm	S4%	Cycles	Starts	60 Hz	50 Hz	60 Hz	50 Hz	60 Hz	50 Hz	Watts
761A00-11390000/A	700	80	40	120	1200	17	20	1.2	1.1	1.4	1.3	15
761B00-11390000/A	880	100	40	100	1200	19	23	1.3	1.2	1.4	1.3	
762A00-11390000/A	1,330	150	50	120	1200	18	21	2.3	2.3	2.5	2.4	40
762B00-11390000/A	1,750	200	35	80	1200	25	30	2.3	2.3	2.5	2.4	
763A00-11390000/A	2,650	300	50	80	1200	25	31	2.6	2.5	2.9	3.0	
763B00-11390000/A	4,400	500	30	80	1200	26	32	4.8	4.6	5.0	4.9	90
763C00-11390000/A	5,300	600	30	60	1200	33	39	4.8	4.6	5.0	4.9	
764A00-11390000/A	7,080	800	25	70	1200	30	36	6.5	6.5	7.3	7.4	180
764B00-11390000/A	10,600	1,200	25	50	1200	36	43	6.8	6.8	7.3	7.4	
765A00-11390000/A	17,700	2,000	25	30	1200	88	106	6.8	6.8	7.4	7.4	
765B00-11390000/A	26,500	3,000	25	20	1200	108	130	7.0	7.0	7.3	7.4	

220V - 3 Phase Power

Base Part Number	Output Torque		Duty Cycle	Cycles per Hour	Starts per Hour	Operating Speed (sec)		Full Load Current (FLA) [A]		Locked Rotor Current (LRA) [A]		Motor Power
	In-Lbs.	Nm	S4%	Cycles	Starts	60 Hz	50 Hz	60 Hz	50 Hz	60 Hz	50 Hz	Watts
761A00-11330C00/A												
761B00-11330C00/A												
762A00-11330C00/A												
762B00-11330C00/A												
763A00-11330C00/A	2,650	300	70	80	1200	26	32	1.0	1.0	1.2	1.2	40
763B00-11330C00/A	4,400	500	70	80	1200	26	32	2.0	2.0	2.4	2.4	90
763C00-11330C00/A	5,300	600	70	60	1200	32	39	2.0	2.0	2.4	2.4	
764A00-11330C00/A	7,080	800	70	70	1200	29	35	3.4	3.4	4.0	4.0	180
764B00-11330C00/A	10,600	1,200	70	50	1200	36	43	3.4	3.4	4.0	4.0	
765A00-11330C00/A	17,700	2,000	50	30	1200	88	105	3.4	3.4	4.0	4.0	
765B00-11330C00/A	26,500	3,000	50	20	1200	108	130	3.4	3.4	4.0	4.0	

NOTES

1. Full load current (FLA) @ Max. rated load
2. Locked rotor current (LRA) @ Locked rotor load
3. Allowable motor voltage tolerance: +/- 10%
4. Allowable power frequency tolerance: +/- 5%
5. Duty cycle per IEC 60034-1 for on/off and modulating service
6. Starts and cycles per hour based on rated torque

WEATHERPROOF - CE & UKCA

380V - 3 Phase Power

Base Part Number	Output Torque		Duty Cycle	Cycles per Hour	Starts per Hour	Operating Speed (sec)		Full Load Current (FLA) [A]		Locked Rotor Current (LRA) [A]		Motor Power
	In-Lbs.	Nm	S4%	Cycles	Starts	60 Hz	50 Hz	60 Hz	50 Hz	60 Hz	50 Hz	Watts
761A00-11340C00/A	700	80	70	120	1200	17	20	0.3	0.3	0.5	0.5	15
761B00-11340C00/A	880	100	70	100	1200	21	25	0.3	0.3	0.5	0.5	
762A00-11340C00/A	1,330	150	70	120	1200	18	21	0.6	0.6	0.7	0.7	40
762B00-11340C00/A	1,750	200	70	80	1200	26	32	0.6	0.6	0.7	0.7	
763A00-11340C00/A	2,650	300	70	80	1200	26	32	0.6	0.6	0.8	0.8	90
763B00-11340C00/A	4,400	500	70	80	1200	26	32	0.9	0.9	1.4	1.4	
763C00-11340C00/A	5,300	600	70	60	1200	32	39	1.0	1.0	1.4	1.4	180
764A00-11340C00/A	7,080	800	70	70	1200	29	35	1.4	1.4	2.4	2.4	
764B00-11340C00/A	10,600	1,200	70	50	1200	36	43	1.7	1.7	2.4	2.4	180
765A00-11340C00/A	17,700	2,000	50	30	1200	88	105	1.4	1.4	2.4	2.4	
765B00-11340C00/A	26,500	3,000	50	20	1200	108	130	1.7	1.7	2.4	2.4	700
766A00-11340C00/A	31,000	3,500	40	110	960	33	39	4.2	4.2	9.9	9.9	
766B00-11340C00/A	35,400	4,000	40	70	960	49	58	4.2	4.2	9.9	9.9	700
767A00-11340C00/A	53,100	6,000	40	50	960	66	78	3.6	3.6	9.9	9.9	
767B00-11340C00/A	70,800	8,000	40	30	960	98	116	3.6	3.6	9.9	9.9	700
767C00-11340C00/A	79,700	9,000	40	30	960	99	117	3.6	3.6	9.9	9.9	

460V - 3 Phase Power

Base Part Number	Output Torque		Duty Cycle	Cycles per Hour	Starts per Hour	Operating Speed (sec)		Full Load Current (FLA) [A]		Locked Rotor Current (LRA) [A]		Motor Power
	In-Lbs.	Nm	S4%	Cycles	Starts	60 Hz	50 Hz	60 Hz	50 Hz	60 Hz	50 Hz	Watts
761A00-11360C00/A												
761B00-11360C00/A												
762A00-11360C00/A	1,330	150	70	120	1200	18	21	0.4	0.4	0.5	0.5	40
762B00-11360C00/A	1,750	200	70	80	1200	26	32	0.4	0.4	0.5	0.5	
763A00-11360C00/A	2,650	300	70	80	1200	26	32	0.4	0.4	0.6	0.6	90
763B00-11360C00/A	4,400	500	70	80	1200	26	32	0.7	0.7	1.3	1.3	
763C00-11360C00/A	5,300	600	70	60	1200	32	39	1.0	1.0	1.3	1.3	180
764A00-11360C00/A	7,080	800	70	70	1200	29	35	1.3	1.3	2.0	2.0	
764B00-11360C00/A	10,600	1,200	70	50	1200	36	43	1.4	1.4	2.0	2.0	180
765A00-11360C00/A	17,700	2,000	50	30	1200	88	105	1.3	1.3	2.0	2.0	
765B00-11360C00/A	26,500	3,000	50	20	1200	108	130	1.4	1.4	2.0	2.0	

NOTES

1. Full load current (FLA) @ Max. rated load
2. Locked rotor current (LRA) @ Locked rotor load
3. Allowable motor voltage tolerance: +/- 10%
4. Allowable power frequency tolerance: +/- 5%
5. Duty cycle per IEC 60034-1 for on/off and modulating service
6. Starts and cycles per hour based on rated torque

EXPLOSIONPROOF - CSA

24V AC/DC Power - On/Off

Base Part Number	On/Off Output Torque		On/Off Duty Cycle	Cycles per Hour	Operating Speed	Full Load Current (FLA)	Locked Rotor Current (LRA)	Motor Power
	In-Lbs.	Nm	S4%	Cycles	Sec	Amps	Amps	Watts
761X30-11380000/A	620	70	30	350	17	5.0	12.8	40
761Y30-11380000/A	700	80	30	300	20	6.3	12.8	
762X30-11380000/A	1,350	150	40	200	22	6.0	16.9	
762Y30-11380000/A	1,410	160	40	200	22	7.4	16.9	
763X30-11380000/A	2,120	240	35	160	32	8.9	30.8	

24V DC Power - Modulating

Base Part Number	Modulating Output Torque		Modulating Duty Cycle	Starts per Hour	Operating Speed	Full Load Current (FLA)	Locked Rotor Current (LRA)	Motor Power
	In-Lbs.	Nm	S4%	Starts	Sec	Amps	Amps	Watts
761X30-11370000/A	560	65	30	720	17	5.0	12.8	40
761Y30-11370000/A	630	72	30	720	20	6.3	12.8	
762X30-11370000/A	1,150	130	40	960	22	6.0	16.9	
762Y30-11370000/A	1,270	145	40	960	22	7.4	16.9	
763X30-11370000/A	1,900	220	35	840	32	8.9	30.8	

NOTES

Hazardous Location Certification (Area Classification)
 Class I, Division 1, GRoups C, D; T4
 Ex d IIB T4 Gb
 Class I, Zone 1, AEx d IIB T4 Gb

1. Full load current (FLA) @ Max. rated load
2. Locked rotor current (LRA) @ Locked rotor load
3. Allowable motor voltage tolerance: +/- 10%
4. Allowable power frequency tolerance: +/- 5%
5. Duty cycle per IEC 60034-1 for on/off and modulating service
6. Starts and cycles per hour based on rated torque

ELECTRICAL DATA

EXPLOSIONPROOF - CSA

110V - Single Phase Power

Base Part Number	On/Off Output Torque		On/Off Duty Cycle		Cycles per Hour		Modulating Output Torque		Modulating Duty Cycle		Starts per Hour	Operating Speed (sec)		Full Load Current (FLA) [A]		Locked Rotor Current (LRA) [A]		Motor Power Watts
	In-Lbs.	Nm	S4%	Cycles	In-Lbs.	Nm	S4%	Starts	60 Hz	50 Hz		60 Hz	50 Hz	60 Hz	50 Hz	60 Hz	50 Hz	
761X30-11300000/A	690	80	40	190	550	65	40	960	20	23	1.2	1.1	1.4	1.3			15	
761Y30-11300000/A	860	100	40	190	680	80	40	960	20	23	1.2	1.1	1.4	1.3				
762X30-11300000/A	1,350	150	70	100	1,150	130	40	960	21	25	2.0	1.9	2.5	2.4			40	
762Y30-11300000/A	1,770	200	70	100	1,360	160	40	960	21	25	2.3	2.2	2.5	2.4				
763X30-11300000/A	2,640	300	70	80	2,110	240	40	960	26	31	2.3	2.0	2.9	3.0			90	
763Y30-11300000/A	3,980	450	30	170	3,180	360	30	720	29	35	4.5	3.8	5.0	4.9				
764X30-11300000/A	6,900	800	30	160	5,520	640	30	720	31	37	5.1	5.0	7.3	7.4			180	
764Y30-11300000/A	9,600	1,100	30	160	7,680	880	30	720	31	37	5.4	5.4	7.3	7.4				
765X30-11300000/A	17,500	2,000	30	50	14,000	1,600	30	720	93	112	5.8	5.7	7.3	7.4				
765Y30-11300000/A	25,900	3,000	30	50	20,720	2,400	30	720	93	112	6.3	6.3	7.3	7.4				

220V - Single Phase Power

Base Part Number	On/Off Output Torque		On/Off Duty Cycle		Cycles per Hour		Modulating Output Torque		Modulating Duty Cycle		Starts per Hour	Operating Speed (sec)		Full Load Current (FLA) [A]		Locked Rotor Current (LRA) [A]		Motor Power Watts
	In-Lbs.	Nm	S4%	Cycles	In-Lbs.	Nm	S4%	Starts	60 Hz	50 Hz		60 Hz	50 Hz	60 Hz	50 Hz	60 Hz	50 Hz	
761X30-11320000/A	690	80	40	190	550	65	40	960	20	23	0.6	0.6	0.7	0.7			15	
761Y30-11320000/A	790	90	40	190	630	72	40	960	20	23	0.6	0.6	0.7	0.7				
762X30-11320000/A	1,350	150	35	180	1,150	130	40	960	23	28	1.0	0.9	1.2	1.1			40	
762Y30-11320000/A	1,590	180	35	180	1,270	145	40	960	23	28	1.1	1.0	1.2	1.1				
763X30-11320000/A	2,300	260	40	140	1,900	220	40	960	26	31	1.3	1.3	1.4	1.5			90	
763Y30-11320000/A	3,980	450	30	170	3,180	360	30	720	29	35	1.9	1.5	2.4	2.5				
764X30-11320000/A	6,900	800	30	140	5,520	640	30	720	34	41	2.4	2.2	3.8	3.9			180	
764Y30-11320000/A	8,300	940	30	140	6,640	750	30	720	34	41	3.4	3.3	3.8	3.9				
765X30-11320000/A	17,500	2,000	30	50	14,000	1,600	30	720	93	112	2.4	2.2	3.8	3.9				
765Y30-11320000/A	25,900	3,000	30	50	20,720	2,400	30	720	93	112	3.4	3.3	3.8	3.9				

NOTES:

- Hazardous Location Certification (Area Classification)
 - Class I, Division 1, Groups C, D; T4
 - Ex d IIB T4 Gb
 - Class I, Zone 1, AEx d IIB T4 Gb
- Full load current (FLA) @ Max. rated load
- Locked rotor current (LRA) @ Locked rotor load
- Allowable motor voltage tolerance: +/- 10%
- Allowable power frequency tolerance: +/- 5%
- Duty cycle per IEC 60034-1 for on/off and modulating service
- Starts and cycles per hour based on rated torque

EXPLOSIONPROOF - IECEX/ATEX

24V AC/DC Power - On/Off

Base Part Number	On/Off Output Torque		On/Off Duty Cycle	Cycles per Hour	Operating Speed	Full Load Current (FLA)	Locked Rotor Current (LRA)	Motor Power
	In-Lbs.	Nm	S4%	Cycles	Sec	Amps	Amps	Watts
761X40-11380000/A	700	80	70	150	17	3.7	12.8	40
761Y40-11380000/A	880	100	70	120	20	4.0	12.8	
762X40-11380000/A	1,330	150	70	110	22	5.3	16.9	
762Y40-11380000/A	1,750	200	70	110	22	6.5	16.9	
763X40-11380000/A	2,650	300	70	80	32	8.6	30.8	

24V DC Power - Modulating

Base Part Number	Modulating Output Torque		Modulating Duty Cycle	Starts per Hour	Operating Speed	Full Load Current (FLA)	Locked Rotor Current (LRA)	Motor Power
	In-Lbs.	Nm	S4%	Starts	Sec	Amps	Amps	Watts
761X40-11370000/A	700	80	70	1200	17	3.7	12.8	40
761Y40-11370000/A	880	100	70	1200	20	4.0	12.8	
762X40-11370000/A	1,330	150	70	1200	22	5.3	16.9	
762Y40-11370000/A	1,750	200	70	1200	22	6.5	16.9	
763X40-11370000/A	2,650	300	70	1200	32	8.6	30.8	

NOTES

- ATEX/IECEX Hazardous Location Certification (Area Classification)
 II 2G Ex db IIB T4 Gb
 II 2D Ex tb IIIC T135°C Db
- Full load current (FLA) @ Max. rated load
- Locked rotor current (LRA) @ Locked rotor load
- Allowable motor voltage tolerance: +/- 10%
- Allowable power frequency tolerance: +/- 5%
- Duty cycle per IEC 60034-1 for on/off and modulating service
- Starts and cycles per hour based on rated torque

EXPLOSIONPROOF - IECEx/ATEX

110V - Single Phase Power

Base Part Number	Output Torque		Duty Cycle	Cycles per Hour	Starts per Hour	Operating Speed (sec)		Full Load Current (FLA) [A]		Locked Rotor Current (LRA) [A]		Motor Power
	In-Lbs.	Nm				60 Hz	50 Hz	60 Hz	50 Hz	60 Hz	50 Hz	
761X40-11300000/A	700	80	70	110	1200	20	23	1.1	1.2	1.3	1.3	15
761Y40-11300000/A	880	100	70	110	1200	20	23	1.1	1.2	1.3	1.3	
762X40-11300000/A	1,330	150	70	100	1200	21	25	2.0	2.1	2.4	2.4	40
762Y40-11300000/A	1,750	200	70	100	1200	21	25	2.1	2.2	2.4	2.4	
763X40-11300000/A	2,650	300	70	80	1200	26	31	2.4	2.1	2.9	2.9	90
763Y40-11300000/A	4,400	500	70	70	1200	29	35	4.2	3.3	4.9	4.9	
763Z40-11300000/A	5,300	600	70	70	1200	29	35	4.4	3.4	4.9	4.9	180
764X40-11300000/A	7,080	800	70	60	1200	31	37	5.7	5.4	7.3	7.3	
764Y40-11300000/A	10,600	1,200	70	60	1200	31	37	6.9	6.5	7.3	7.3	
765X40-11300000/A	17,700	2,000	50	30	1200	93	112	5.7	5.4	7.3	7.3	180
765Y40-11300000/A	26,500	3,000	50	30	1200	93	112	6.9	6.5	7.3	7.3	

220V - Single Phase Power

Base Part Number	Output Torque		Duty Cycle	Cycles per Hour	Starts per Hour	Operating Speed (sec)		Full Load Current (FLA) [A]		Locked Rotor Current (LRA) [A]		Motor Power
	In-Lbs.	Nm				60 Hz	50 Hz	60 Hz	50 Hz	60 Hz	50 Hz	
761X40-11320000/A	700	80	70	110	1200	20	23	0.6	0.6	0.7	0.7	15
761Y40-11320000/A	880	100	70	110	1200	20	23	0.6	0.7	0.7	0.7	
762X40-11320000/A	1,330	150	70	90	1200	23	28	1.0	1.0	1.0	1.0	40
762Y40-11320000/A	1,750	200	70	90	1200	23	28	1.1	1.1	1.1	1.1	
763X40-11320000/A	2,650	300	70	80	1200	26	31	1.3	1.0	1.5	1.5	90
763Y40-11320000/A	4,400	500	70	70	1200	29	35	1.9	1.7	2.4	2.4	
763Z40-11320000/A	5,300	600	70	70	1200	29	35	2.0	1.9	2.4	2.4	180
764X40-11320000/A	7,080	800	70	60	1200	34	41	2.8	2.6	3.8	3.8	
764Y40-11320000/A	10,600	1,200	70	60	1200	34	41	3.0	2.8	3.8	3.8	
765X40-11320000/A	17,700	2,000	50	30	1200	93	112	3.0	3.1	3.8	3.8	180
765Y40-11320000/A	26,500	3,000	50	30	1200	93	112	3.0	2.8	3.8	3.8	

NOTES

- ATEX/IECEX Hazardous Location Certification (Area Classification)
II 2G Ex db IIB T4 Gb
II 2D Ex tb IIIC T135°C Db
- Full load current (FLA) @ Max. rated load
- Locked rotor current (LRA) @ Locked rotor load
- Allowable motor voltage tolerance: +/- 10%
- Allowable power frequency tolerance: +/- 5%
- Duty cycle per IEC 60034-1 for on/off and modulating service
- Starts and cycles per hour based on rated torque

EXPLOSIONPROOF - IECEX/ATEX

220V - 3 Phase Power

Base Part Number	Output Torque		Duty Cycle	Cycles per Hour	Starts per Hour	Operating Speed (sec)		Full Load Current (FLA) [A]		Locked Rotor Current (LRA) [A]		Motor Power
	In-Lbs.	Nm	S4%	Cycles	Starts	60 Hz	50 Hz	60 Hz	50 Hz	60 Hz	50 Hz	Watts
761X40-11330C00/A	N/A											
761Y40-11330C00/A	N/A											
762X40-11330C00/A	N/A											
762Y40-11330C00/A	N/A											
763X40-11330C00/A	2,650	300	70	80	1200	26	32	0.4	0.5	1.2	1.2	40
763Y40-11330C00/A	4,400	500	70	80	1200	26	32	0.7	0.9	2.4	2.4	90
763Z40-11330C00/A	5,300	600	70	60	1200	32	39	0.7	0.9	2.4	2.4	
764X40-11330C00/A	7,080	800	70	70	1200	29	35	1.0	1.4	4.0	4.0	180
764Y40-11330C00/A	10,600	1,200	70	50	1200	36	43	1.0	1.4	4.0	4.0	
765X40-11330C00/A	17,700	2,000	50	30	1200	88	105	1.0	1.4	4.0	4.0	
765Y40-11330C00/A	26,500	3,000	50	20	1200	108	130	1.0	1.4	4.0	4.0	

380V - 3 Phase Power

Base Part Number	Output Torque		Duty Cycle	Cycles per Hour	Starts per Hour	Operating Speed (sec)		Full Load Current (FLA) [A]		Locked Rotor Current (LRA) [A]		Motor Power
	In-Lbs.	Nm	S4%	Cycles	Starts	60 Hz	50 Hz	60 Hz	50 Hz	60 Hz	50 Hz	Watts
761X40-11340C00/A	700	80	70	120	1200	17	20	0.3	0.2	0.5	0.5	15
761Y40-11340C00/A	880	100	70	100	1200	21	25	0.3	0.2	0.5	0.5	
762X40-11340C00/A	1,330	150	70	120	1200	18	21	0.4	0.6	0.7	0.7	40
762Y40-11340C00/A	1,750	200	70	80	1200	26	32	0.5	0.7	0.7	0.7	
763X40-11340C00/A	2,650	300	70	80	1200	26	32	0.5	0.6	0.8	0.8	90
763Y40-11340C00/A	4,400	500	70	80	1200	26	32	0.8	0.9	1.4	1.4	
763Z40-11340C00/A	5,300	600	70	60	1200	32	39	0.9	1.0	1.4	1.4	
764X40-11340C00/A	7,080	800	70	70	1200	29	35	1.0	1.3	2.4	2.4	
764Y40-11340C00/A	10,600	1,200	70	50	1200	36	43	1.1	1.5	2.4	2.4	180
765X40-11340C00/A	17,700	2,000	50	30	1200	88	105	1.0	1.4	2.4	2.4	
765Y40-11340C00/A	26,500	3,000	50	20	1200	108	130	1.1	1.5	2.4	2.4	

460V - 3 Phase Power

Base Part Number	Output Torque		Duty Cycle	Cycles per Hour	Starts per Hour	Operating Speed (sec)		Full Load Current (FLA) [A]		Locked Rotor Current (LRA) [A]		Motor Power
	In-Lbs.	Nm	S4%	Cycles	Starts	60 Hz	50 Hz	60 Hz	50 Hz	60 Hz	50 Hz	Watts
761X40-11360C00/A	N/A											
761Y40-11360C00/A	N/A											
762X40-11360C00/A	1,330	150	70	120	1200	18	21	0.4	0.6	0.5	0.5	40
762Y40-11360C00/A	1,750	200	70	80	1200	26	32	0.4	0.6	0.5	0.5	
763X40-11360C00/A	2,650	300	70	80	1200	26	32	0.3	0.4	0.6	0.6	90
763Y40-11360C00/A	4,400	500	70	80	1200	26	32	0.5	0.7	1.3	1.3	
763Z40-11360C00/A	5,300	600	70	60	1200	32	39	0.9	1.3	1.3	1.3	
764X40-11360C00/A	7,080	800	70	70	1200	29	35	0.9	1.6	2.0	2.0	
764Y40-11360C00/A	10,600	1,200	70	50	1200	36	43	0.9	1.7	2.0	2.0	180
765X40-11360C00/A	17,700	2,000	50	30	1200	88	105	0.9	1.6	2.0	2.0	
765Y40-11360C00/A	26,500	3,000	50	20	1200	108	130	0.9	1.7	2.0	2.0	

NOTES

- ATEX/IECEX Hazardous Location Certification (Area Classification)
 - II 2G Ex db IIB T4 Gb
 - II 2D Ex tb IIIC T135°C Db
- Full load current (FLA) @ Max. rated load
- Locked rotor current (LRA) @ Locked rotor load
- Allowable motor voltage tolerance: +/- 10%
- Allowable power frequency tolerance: +/- 5%
- Duty cycle per IEC 60034-1 for on/off and modulating service
- Starts and cycles per hour based on rated torque

WEATHERPROOF

Actuator Model	Handwheel Turns	Handwheel Diameter		Rim Pull		Actuator Weight	
		in	mm	lbs.	N	lbs.	kg.
1A	11	4.48	114	23	101	19	9
1B				28	127		
2A	11	4.84	123	40	176	33	15
2B				53	235		
3A	13.5	8.66	220	36	160	47	22
3B				60	267		
3C				72	321		
4A	15	14.96	380	50	223	66	30
4B				75	334		
5A	45	14.96	380	46	206	157	71
5B				70	309		
6A	52.5	14.96	380	63	278	165	75
6B				72	318		
7A	105	14.96	380	60	265	474	215
7B				79	354		
7C	157.5	14.96	380	60	265	474	215

EXPLOSIONPROOF

Actuator Model	Handwheel Turns	Handwheel Diameter		Rim Pull		Actuator Weight	
		in	mm	lbs.	N	lbs.	kg.
1X	10.3*	4.48	114	26	115	15	7
1Y	12.3*			27	122		
2X	11	4.84	123	36	158	37	17
2Y				47	211		
3X	13.5	8.66	220	32	144	51	23
3Y				54	240		
3Z				65	289		
4X	16.5	14.96	380	41	182	64	29
4Y				60	273		
5X	49.5	14.96	380	38	169	165	75
5Y				57	253		

NOTES:

1. Torque ratings dependent of certification and power voltage.
2. Handwheel to Actuator Output: Actuator shall be designed to produce the required operating torque with a maximum rim pull of 80 lb. (356 N) on the handwheel.
3. *Size 1X and 1Y have 8.8 and 10.3 handwheel turns (respectively) for ATEX/IECEx units.

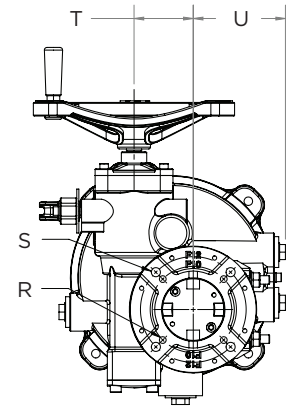
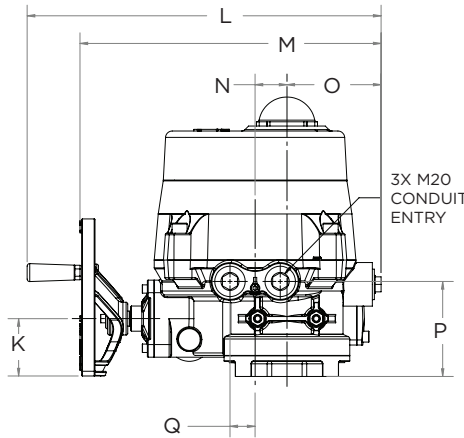
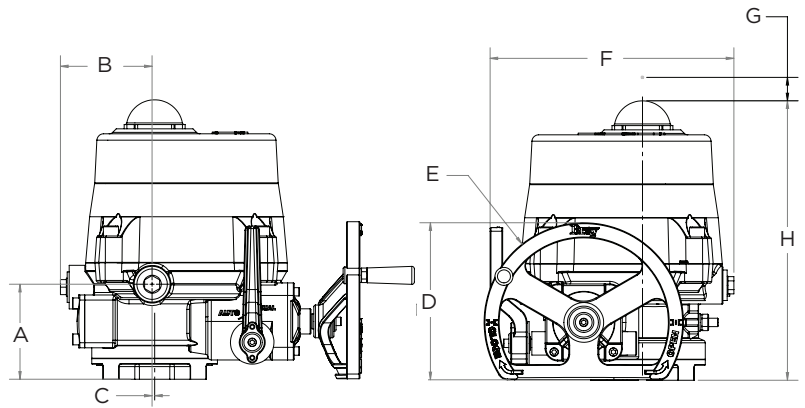
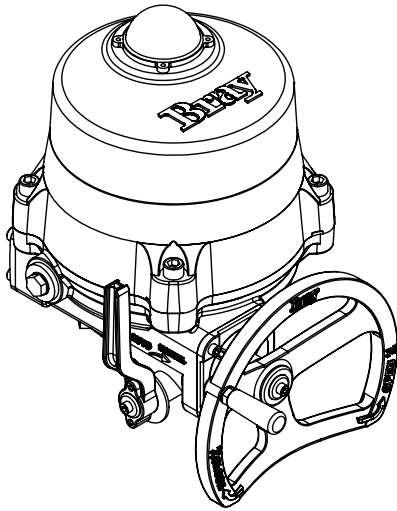

BUSHING DETAILS

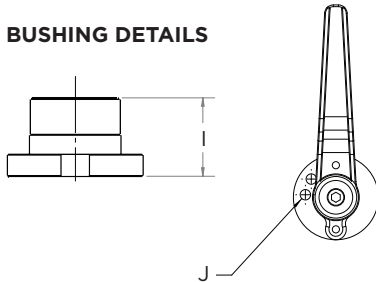

IMPERIAL (in)

ACT. DIMENSIONS SIZE

MSS-101

	A	B	C	D	E	F	G	H	I	J	K	L	M	N	O	P	Q	T	U	DIM	FLNG.	B.C.D.	TAP SZ	MIN DEPTH
1	3.7	3.4	0.1	4.6	5.1	8.3	4.9	10.4	1.1	0.23	2.1	11.9	9.9	1.0	3.2	3.7	0.9	1.9	3.5	R	FA07	2.75	5/16-18	0.472
2	4.4	3.7	-	5.1	5.5	9.7	5.5	11.8	1.4	0.27	2.7	14.2	11.7	1.2	3.7	4.4	1.2	2.2	3.8	S	FA10	4.00	3/8-16	0.563
																				R	FA07	2.75	5/16-18	0.472
3	4.5	4.3	0.1	7.4	9.4	11.5	6.7	13.1	1.7	0.27	2.7	16.6	14.2	1.5	4.4	4.5	1.2	2.8	4.3	S	FA12	4.95	1/2-13	0.709
																				R	FA10	4.00	3/8-16	0.563
4	4.9	4.5	0.5	12.2	16.7	13.8	7.5	14.5	2.2	0.27	3.2	15.6	-	1.5	5.0	4.9	1.2	3.3	4.6	S	FA14	5.50	5/8-11	0.940
																				R	FA12	4.95	1/2-13	0.709

METRIC (mm)

ACT. DIMENSIONS SIZE

ISO 5211

	A	B	C	D	E	F	G	H	I	J	K	L	M	N	O	P	Q	T	U	DIM	FLNG.	B.C.D.	TAP SZ	MIN DEPTH
1	95	86	3	116	130	211	125	125	28	6	53	303	252	53	82	95	23	49	90	R	F07	70	M8	12
2	113	93	-	130	140	246	140	140	35	7	68	360	297	68	93	113	30	56	96	S	F10	102	M10	15
																				R	F07	70	M8	12
3	113	109	3	188	238	291	170	170	42	7	69	422	359	69	112	113	30	70	109	S	F12	125	M12	18
																				R	F10	102	M10	15
4	125	115	13	309	423	350	190	190	55	7	81	395	-	81	128	125	30	85	118	S	F14	140	M16	24
																				R	F12	125	M12	18

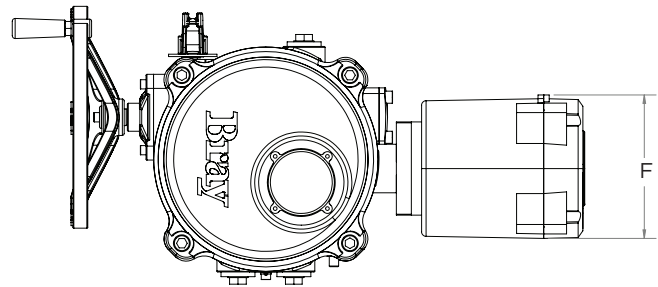
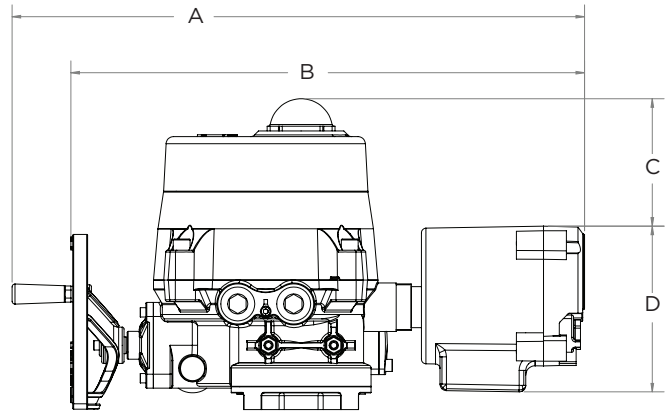
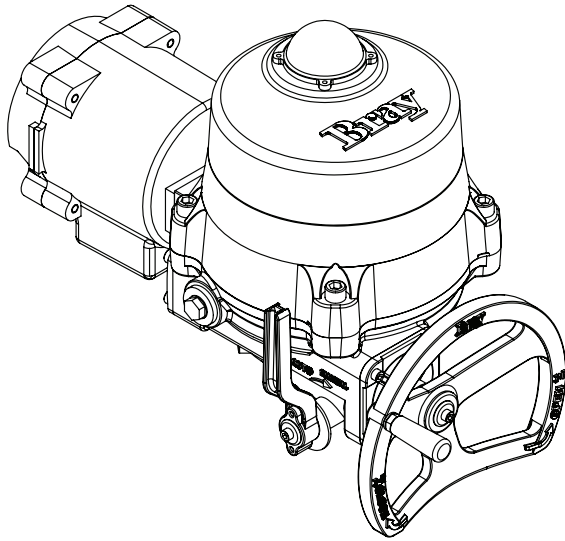

IMPERIAL (in)

ACT. SIZE	DIMENSIONS				
	A	B	C	D	F
1	19.5	17.5	3.5	7.0	6.1
2	21.7	19.2	4.0	7.0	6.1
3	24.2	21.7	5.4	7.0	6.1
4	23.1	-	6.2	7.0	6.1

METRIC (mm)

ACT. SIZE	DIMENSIONS				
	A	B	C	D	F
1	496	443	89	178	154
2	551	487	103	178	154
3	614	551	137	178	154
4	586	-	159	178	154

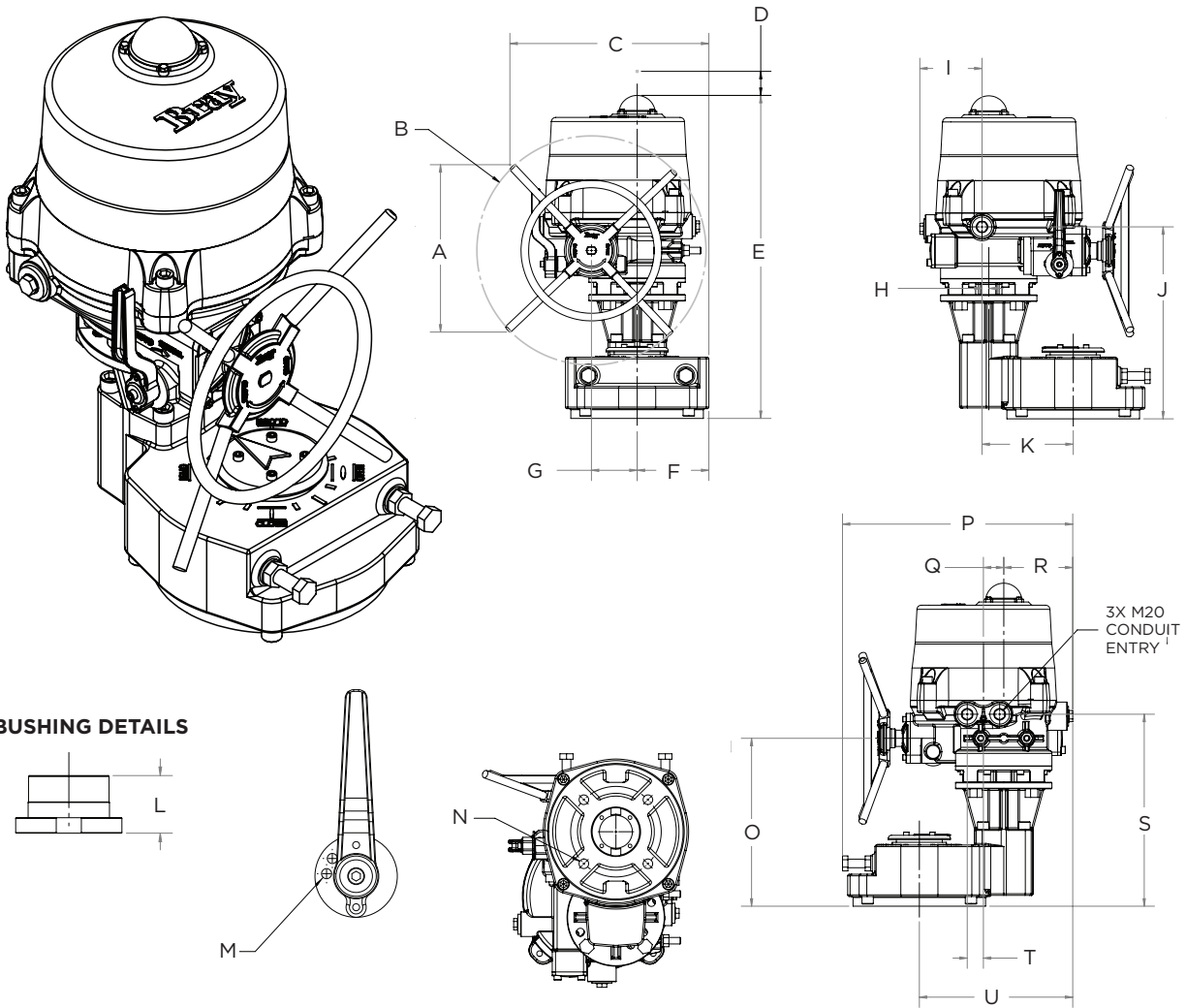

IMPERIAL (in)

ACT. DIMENSIONS																		MSS SP-101							
SIZE	A	B	C	D	E	F	G	H	I	J	K	L	M	O	P	Q	R	S	T	U	DIM	FLNG	B.C.D.	THREAD	MIN. DEPTH
5	12.2	15.7	14.5	7.5	23.5	5.2	3.3	0.5	4.5	14.0	6.6	2.4	0.27	12.2	16.8	1.5	5.0	14.0	1.2	11.2	N	FA16	6.5	3/4-10	1.13

METRIC (mm)

ACT. DIMENSIONS																		ISO 5211							
SIZE	A	B	C	D	E	F	G	H	I	J	K	L	M	O	P	Q	R	S	T	U	DIM	FLNG	B.C.D.	THREAD	MIN. DEPTH
5	309	423	368	190	597	133	84	13	115	355	169	60	7	310	426	38	128	355	30	284	N	F16	165	M20	30

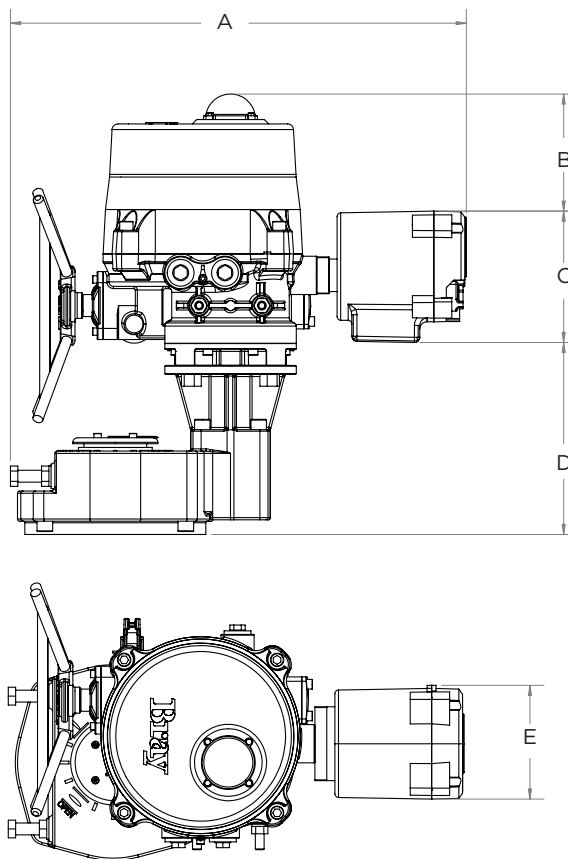
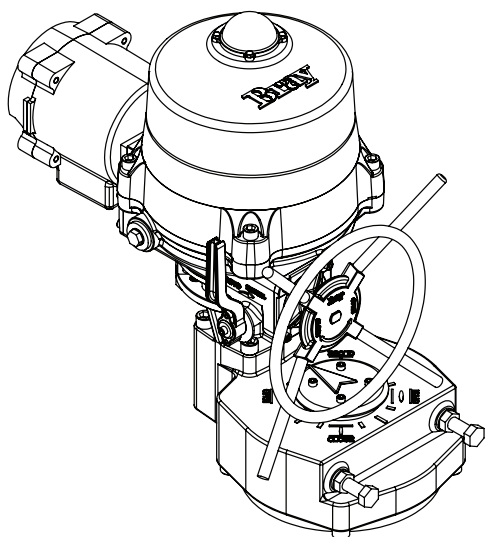

IMPERIAL (in)

ACT. SIZE	DIMENSIONS				
	A	B	C	D	E
5	24.3	6.2	7.0	16.7	6.1

METRIC (mm)

ACT. SIZE	DIMENSIONS				
	A	B	C	D	E
5	617	159	178	424	154

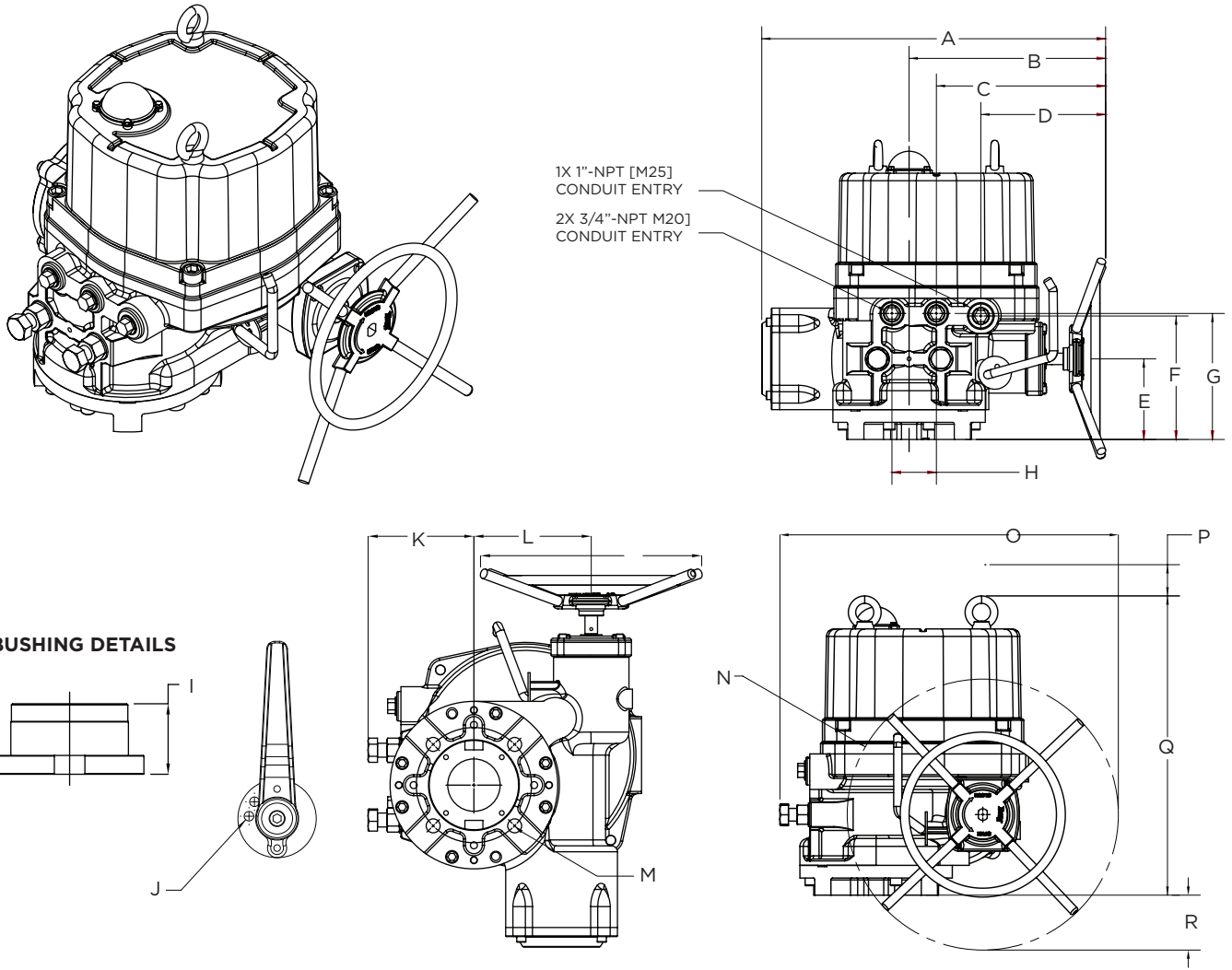

BUSHING DETAILS

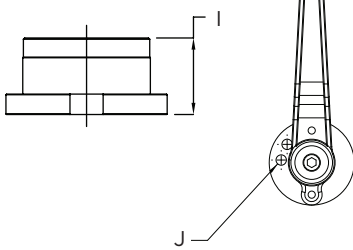

IMPERIAL (in)

ACT. DIMENSIONS SIZE	MSS-101																	MSS-101				
	A	B	C	D	E	F	G	H	I	J	K	L	N	O	P	Q	R	DIM	FLNG.	B.C.D.	TAP SZ	MIN DEPTH
6	20.3	11.1	9.5	6.7	5.0	7.7	7.8	2.8	2.4	0.27	6.0	6.6	16.7	21.0	9.8	18.5	3.3	M	FA16	6.50	3/4-10	1.13

METRIC (mm)

ACT. DIMENSIONS SIZE	ISO 5211																	ISO 5211				
	A	B	C	D	E	F	G	H	I	J	K	L	N	O	P	Q	R	DIM	FLNG.	B.C.D.	TAP SZ	MIN DEPTH
6	515	283	240	170	127	195	199	70	60	7	152	168	424	532	250	471	85	M	F16	165	M20	30

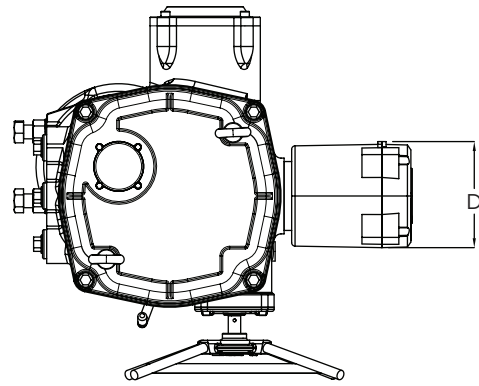
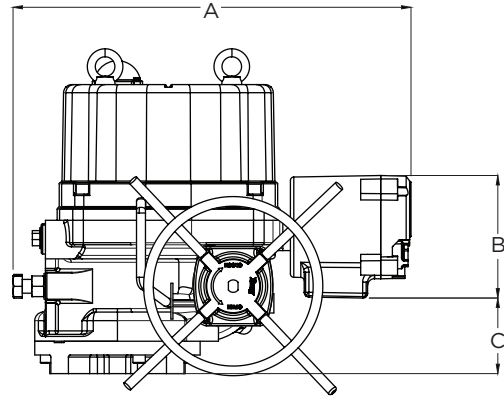
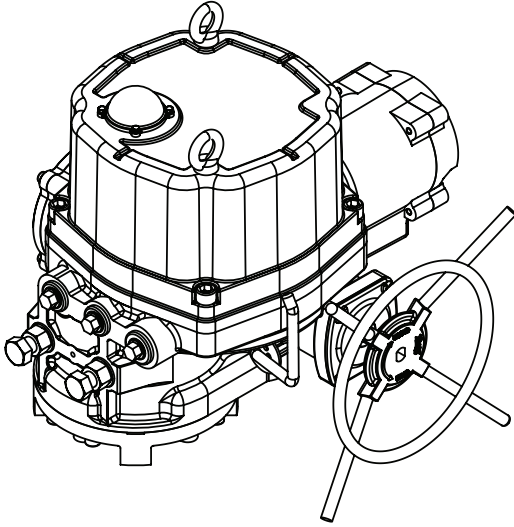

IMPERIAL (in)

ACT. SIZE	DIMENSIONS			
	A	B	C	D
6	22.7	7.0	4.3	6.1

METRIC (mm)

ACT. SIZE	DIMENSIONS			
	A	B	C	D
6	578	178	110	154

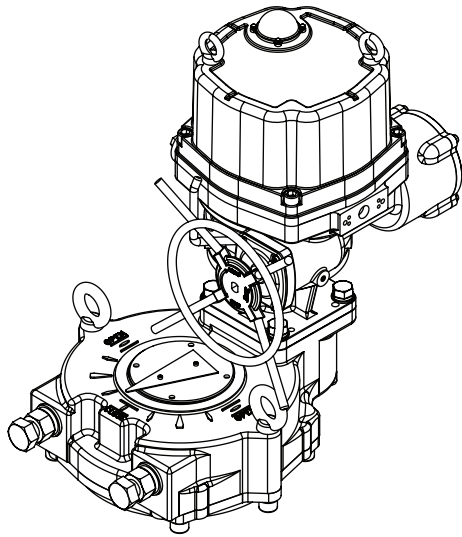

1x1" - NPT [M25]
CONDUIT ENTRY
2x3/4" - NPT [M20]
CONDUIT ENTRY

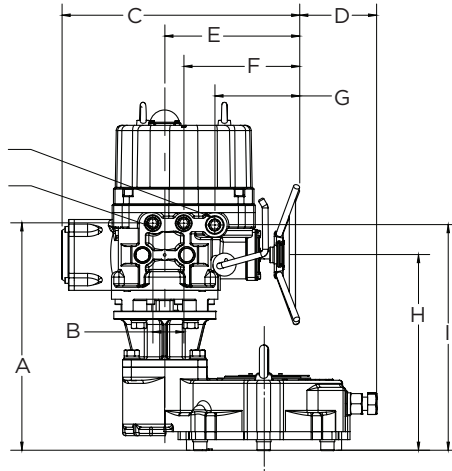

BUSHING DETAILS

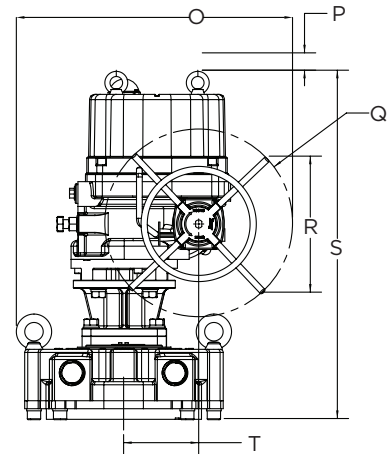
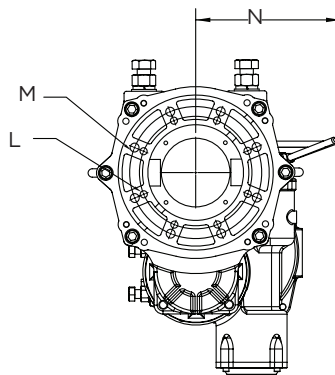
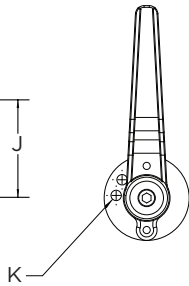
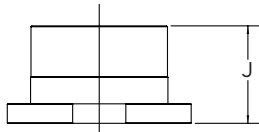

IMPERIAL (in)

ACT. DIMENSIONS																	MSS SP-101						
SIZE	A	B	C	D	E	F	G	H	I	J	K	N	O	P	Q	R	S	T	DIM	FLNG	B.C.D.	THREAD	MIN. DEPTH
7	20.2	2.8	20.3	7.7	11.1	9.5	6.7	17.4	20.1	4.3	0.27	12.8	23.8	9.8	16.7	12.0	30.9	6.6	M	FA30	11.7	3/4-10	1.13
																			L	FA25	10.0	5/8-11	0.94

METRIC (mm)

ACT. DIMENSIONS																	ISO 5211						
SIZE	A	B	C	D	E	F	G	H	I	J	K	N	O	P	Q	R	S	T	DIM	FLNG	B.C.D.	THREAD	MIN. DEPTH
7	513	70	515	196	283	240	170	442	509	110	7	324	605	250	424	305	785	168	M	F30	298	M20	30
																			L	F25	254	M16	24

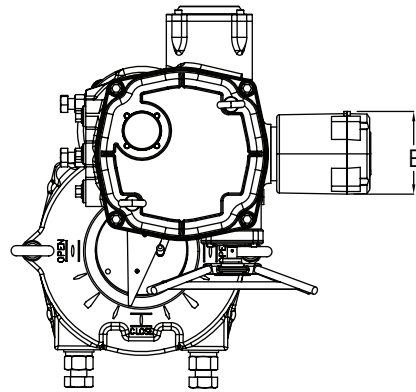
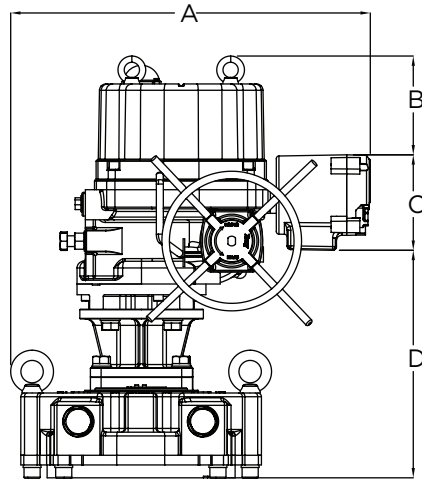
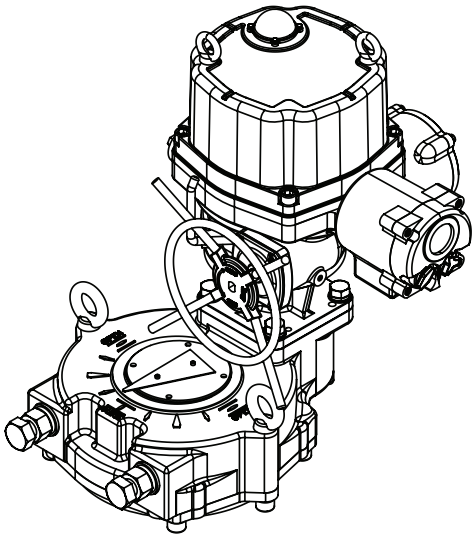

IMPERIAL (in)

ACT. SIZE	DIMENSIONS				
	A	B	C	D	E
7	26.4	7.2	7.0	-	6.1

METRIC (mm)

ACT. SIZE	DIMENSIONS				
	A	B	C	D	E
7	669	184	178	-	154

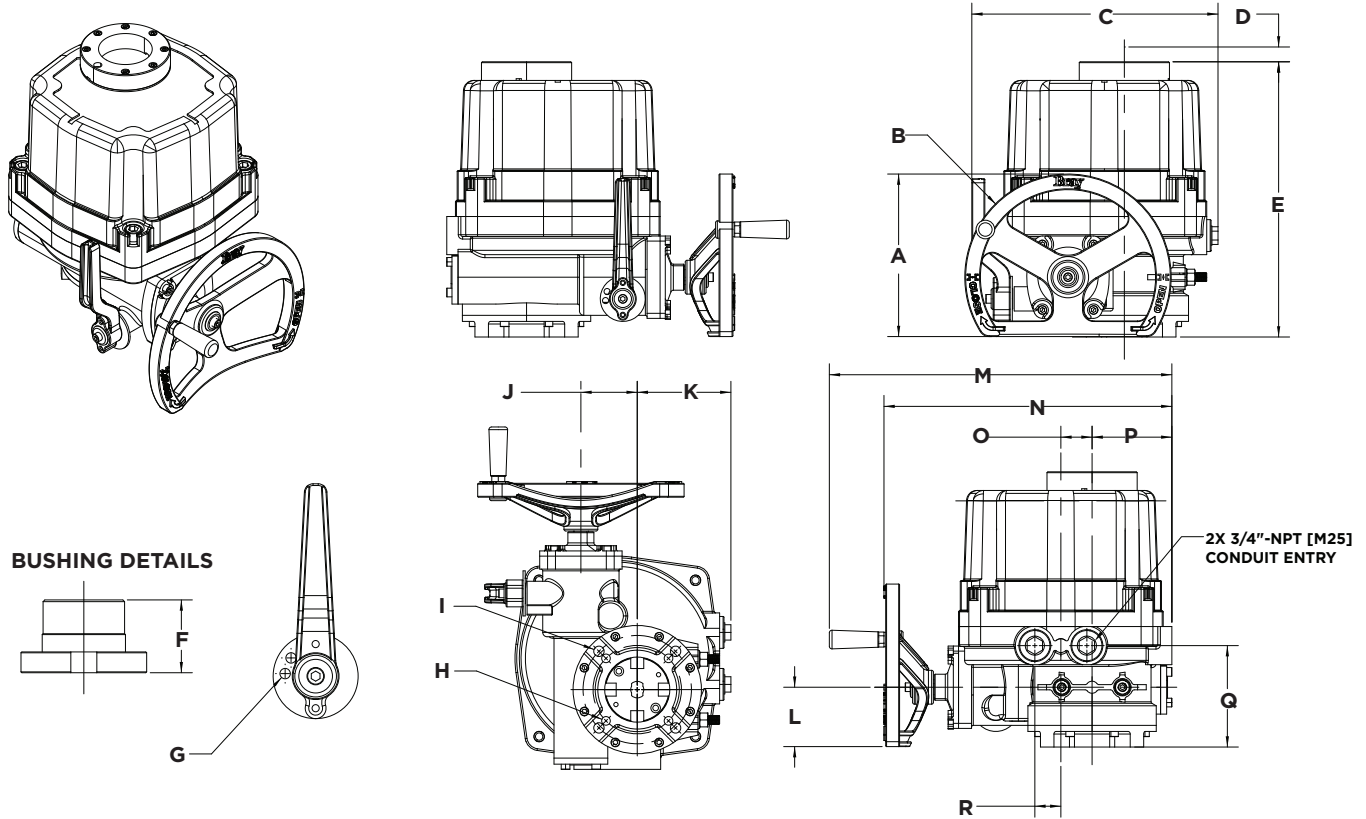

IMPERIAL (in)

ACT. DIMENSIONS																	MSS-101				
SIZE	A	B	C	D	E	F	G	J	K	L	M	N	O	P	Q	R	DIM	FLNG.	B.C.D.	TAP SZ	MIN DEPTH
1	4.6	5.1	7.5	5.3	9.8	1.1	0.23	1.6	3.1	2.0	10.6	8.5	1.1	2.2	3.7	0.9	H	FA07	2.75	5/16-18	0.472
2	5.1	5.5	9.5	5.7	11.1	1.4	0.27	2.1	3.8	2.4	13.9	11.4	1.2	3.3	4.5	1.2	I	FA10	4.00	3/8-16	0.563
3	7.4	9.4	11.2	6.5	12.5	1.7	0.27	2.6	4.3	2.7	15.7	13.2	1.4	3.6	4.6	1.2	H	FA07	2.75	5/16-18	0.472
																	I	FA12	4.95	1/2-13	0.709
4	-	16.7	12.0	8.27	13.5	1.9	0.27	3.1	4.5	-	14.6	-	1.3	4.4	4.8	1.2	I	FA14	5.50	5/8-11	0.940
																	H	FA12	4.95	1/2-13	0.709

METRIC (mm)

ACT. DIMENSIONS																	ISO 5211				
SIZE	A	B	C	D	E	F	G	J	K	L	M	N	O	P	Q	R	DIM	FLNG.	B.C.D.	TAP SZ	MIN DEPTH
1	116	130	191	134	249	28	6	40	79	51	269	216	28	57	95	23	H	F07	70	M8	12
2	130	140	242	145	282	35	7	54	96	60	352	289	30	83	114	30	I	F10	102	M10	15
																	H	F07	70	M8	12
3	188	238	284	165	318	42	7	65	108	69	398	335	36	92	117	30	I	F12	125	M12	18
																	H	F10	102	M10	15
4	-	424	306	210	344	48	7	78	116	-	371	-	32	112	122	30	I	F14	140	M16	24
																	H	F12	125	M12	18

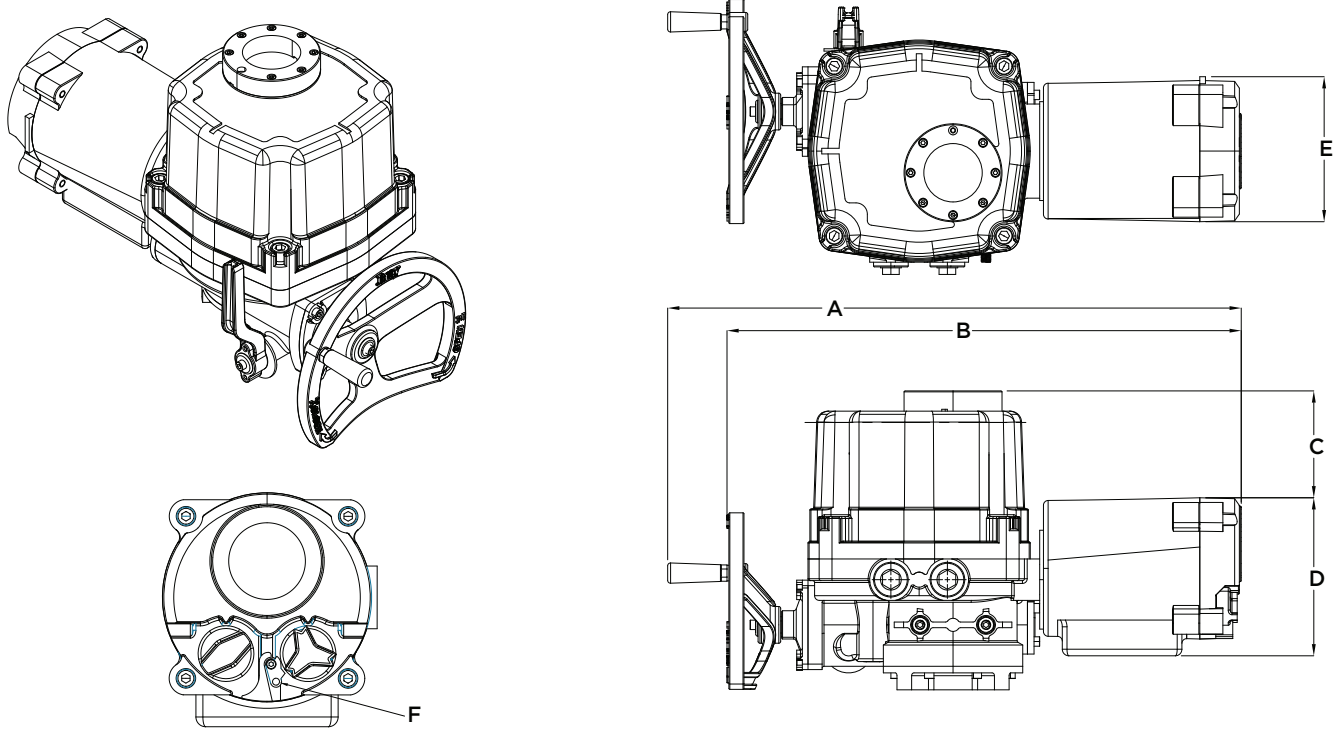

IMPERIAL (in)

ACT. SIZE	DIMENSIONS				
	A	B	C	D	E
1	19.5	17.5	3.5	7.0	6.1
2	21.7	19.2	4.0	7.0	6.1
3	24.2	21.7	5.4	7.0	6.1
4	23.1	-	6.2	7.0	6.1

METRIC (mm)

ACT. SIZE	DIMENSIONS				
	A	B	C	D	E
1	496	443	68.5	178	154
2	568	487	80.5	178	154
3	619	551	113.5	178	154
4	592.5	-	134.5	178	154

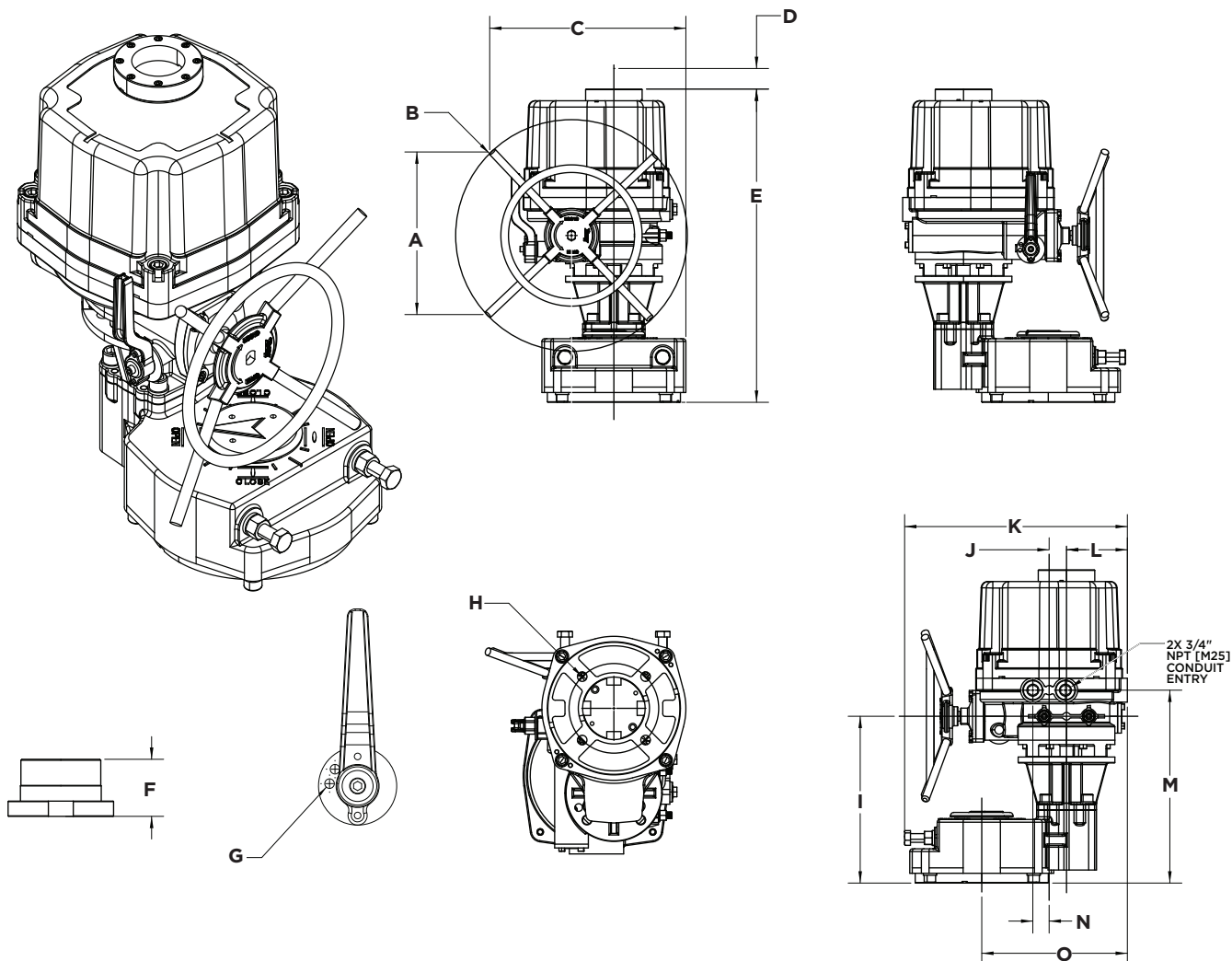

IMPERIAL (in)

ACT. DIMENSIONS SIZE	MSS SP-101																		
	A	B	C	D	E	F	G	H	I	K	L	M	N	O	DIM	FLNG	B.C.D.	THREAD	MIN. DEPTH
5	11.7	16.7	12.7	7.8	22.5	2.4	0.27	11.9	1.3	16.1	4.4	13.8	1.2	10.6	H	FA16	6.50	3/4-10	1.13

METRIC (mm)

ACT. DIMENSIONS SIZE	ISO 5211																		
	A	B	C	D	E	F	G	H	I	K	L	M	N	O	DIM	FLNG	B.C.D.	THREAD	MIN. DEPTH
5	297	424	322	198	573	60	7	303	32	410	112	351	30	268	H	F16	165	M20	30

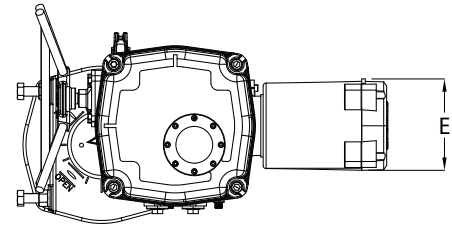
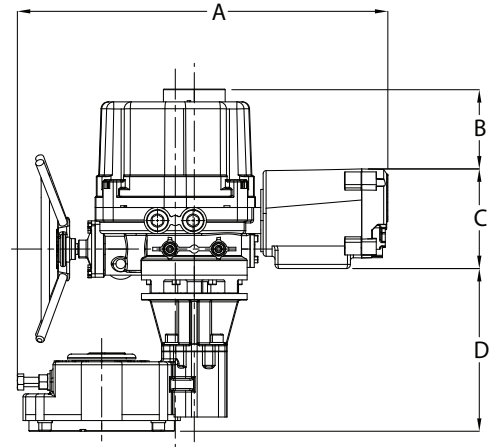
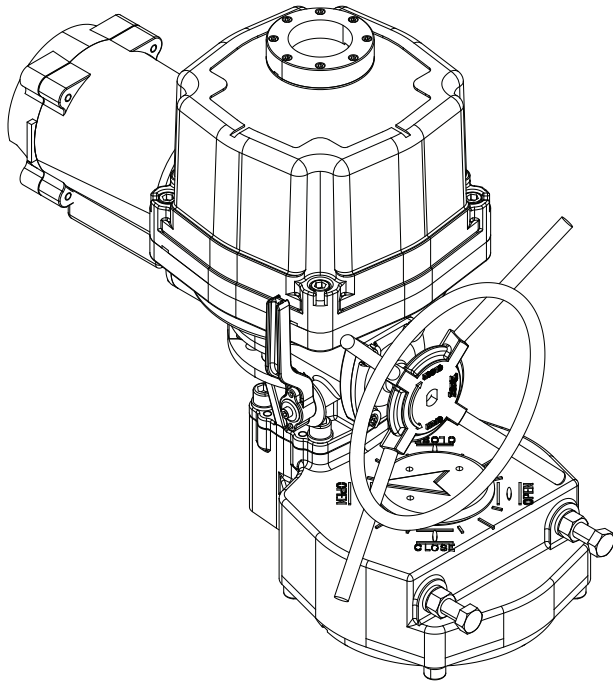

IMPERIAL (in)

ACT. SIZE	DIMENSIONS				
	A	B	C	D	E
5	24.3	6.2	7.0	10.2	6.1

METRIC (mm)

ACT. SIZE	DIMENSIONS				
	A	B	C	D	E
5	617	159	178	260	154

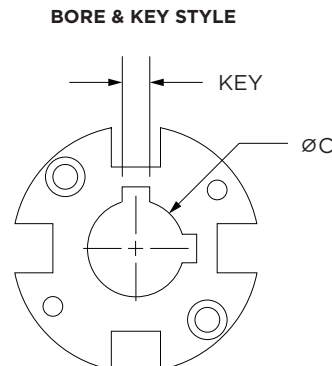
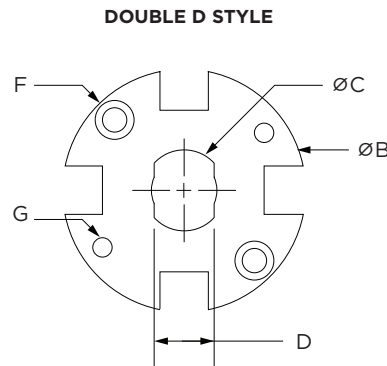
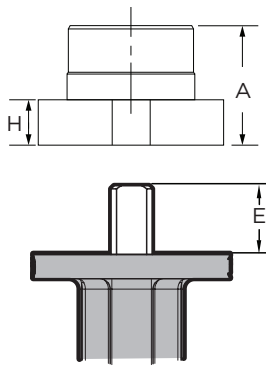

A	BUSHING HEIGHT
B	BUSHING O.D.
C	O.D. OF STEM
D	FLAT OF DD
E	STEM ENGAGEMENT MAX
F	BUSHING MOUNTING BOLT
G	BUSHING PULL THREADS
H	BUSHING PULL THREAD DEPTH

IMPERIAL (in)

SIZE	A	ØB	ØC MAX ¹	E	F	G	H
1	1.102	1.732	0.787	1.378	M4x0.7x.39	M4x0.7	0.315
2	1.378	2.126	0.866	1.772	M5x0.8x.47	M5x0.8	0.394
3	1.654	2.913	1.457	2.047	M6x1.0x.59	M6x1.0	0.472
4	2.165	3.504	1.772	2.638	M8x1.0x.78	M8x1.0	0.827
5	2.362	4.488	2.559	3.740	M8x1.25x.78	M8x1.25	0.630
6	2.362	5.079	3.150	3.150	M8x1.25x.78	M8x1.25	0.630
7	4.331	8.504	4.724	4.685	M10x1.5x1.18	M10x1.5	0.866

METRIC (mm)

SIZE	A	ØB	ØC MAX ¹	E	F	G	H
1	28	44	20	35	M4x0.7x10	M4x0.7	8
2	35	54	22	45	M5x0.8x12	M5x0.8	10
3	46	74	37	52	M6x1.0x15	M6x1.0	12
4	55	89	45	67	M8x1.0x20	M8x1.0	21
5	60	114	65	95	M8x1.25x20	M8x1.25	16
6	77	129	80	80	M8x1.25x20	M8x1.25	16
7	110	216	120	119	M10x1.5x30	M10x1.5	22

HOUSING SIZE	VALVE CODE	STEM DIMENSIONS (in)	
		DOUBLE D [ØC x D]	BORE & KEY SIZE [ØC x KEY]
1	A	0.55 x 0.39	---
	B	0.63 x 0.43	---
	C	0.75 x 0.51	---
2	B	0.63 x 0.4	---
	C	0.75 x 0.5	---
3	C	0.75 x 0.51	---
	D	0.87 x 0.63	---
	E	1.18 x 0.87	---
4	E	1.18 x 0.87	---
	F	---	1.38 w/ 0.39
5	F	---	1.38 w/ 0.39
	G	---	1.97 w/ 0.47 x 0.39
6	G	---	1.97 w/ 0.47 x 0.39
	H	---	2.50 w/ 0.47 x 0.625
7	G	---	1.97 w/ 0.47 x 0.39
	H	---	2.50 w/ 0.625
	F25-2	---	3.00 w/ 0.75

HOUSING SIZE	VALVE CODE	STEM DIMENSIONS (mm)	
		DOUBLE D [ØC x D]	BORE & KEY SIZE [ØC x KEY]
1	A	14 x 10	---
	B	16 x 11	---
	C	19 x 13	---
2	B	16 x 11	---
	C	19 x 13	---
3	C	19 x 13	---
	D	22 x 16	---
	E	30 x 22	---
4	E	30 x 22	---
	F	---	35 w/ 10
5	F	---	35 w/ 10
	G	---	50 w/ 12 x 10
6	G	---	50 w/ 12 x 10
	H	---	63.5 w/ 15.9
7	G	---	50 w/ 12 x 10
	H	---	63.5 w/ 15.9
	F25-2	---	76.2 w/ 19

NOTES

1. Machining outside of the maximum allowable diameter may cause damage to the actuator and void the warranty.
2. Valve codes **A, B, C, D, & E** are Double D type. **F, G, H, & F25-2** are Bore & Key.

GA DRAWINGS NUMBER REFERENCE

WEATHERPROOF	DRAWING NUMBER
Actuator Size 1 with Options, Dimensions	GA-63797
Actuator Size 2 with Options, Dimensions	GA-63870
Actuator Size 3 with Options, Dimensions	GA-63883
Actuator Size 4 with Options, Dimensions	GA-63899
Actuator Size 5 with Options, Dimensions	GA-63902
Actuator Size 6 with Options, Dimensions	GA-63937
Actuator Size 7 with Options, Dimensions	GA-63938
EXPLOSIONPROOF	
Actuator Size 1 with Options, Dimensions	GA-68374
Actuator Size 2 with Options, Dimensions	GA-68375
Actuator Size 3 with Options, Dimensions	GA-68376
Actuator Size 4 with Options, Dimensions	GA-68377
Actuator Size 5 with Options, Dimensions	GA-68378

ACTUATOR WIRING DIAGRAM NUMBER REFERENCE

24V AC/DC POWER

ACT. SIZE	APPLICATION	LOCAL CONTROL STATION	POTENTIOMETER	POSITION TRANSMITTER	ADDITIONAL AUX. LIMIT SWITCHES	ADDITIONAL AUX. TORQUE SWITCHES	WIRING DIAGRAM NUMBER
1	On/Off	NO	NO	NO	NO	NO	WD-000669
2 - 5	On/Off	NO	NO	NO	NO	NO	WD-000667

24V DC POWER

ACT. SIZE	APPLICATION	LOCAL CONTROL STATION	POTENTIOMETER	POSITION TRANSMITTER	ADDITIONAL AUX. LIMIT SWITCHES	ADDITIONAL AUX. TORQUE SWITCHES	WIRING DIAGRAM NUMBER
1	Modulating	NO	YES	NO	NO	NO	WD-000676
1	Modulating	YES	YES	NO	NO	NO	WD-000646
2 - 5	Modulating	NO	YES	NO	NO	NO	WD-000674
2 - 5	Modulating	YES	YES	NO	NO	NO	WD-000630

SINGLE PHASE POWER

ACT. SIZE	APPLICATION	LOCAL CONTROL STATION	POTENTIOMETER	POSITION TRANSMITTER	ADDITIONAL AUX. LIMIT SWITCHES	ADDITIONAL AUX. TORQUE SWITCHES	WIRING DIAGRAM NUMBER
1	On/Off	NO	NO	NO	NO	NO	WD-000683
1	On/Off	YES	NO	NO	NO	NO	WD-000644
2 - 5	On/Off	NO	NO	NO	NO	NO	WD-000661
2 - 5	On/Off	YES	NO	NO	NO	NO	WD-000656
1	Modulating	NO	YES	NO	NO	NO	WD-000682
1	Modulating	YES	YES	NO	NO	NO	WD-000642
2 - 5	Modulating	NO	YES	NO	NO	NO	WD-000680
2 - 5	Modulating	YES	YES	NO	NO	NO	WD-000627

THREE PHASE POWER

ACT. SIZE	APPLICATION	LOCAL CONTROL STATION	POTENTIOMETER	POSITION TRANSMITTER	ADDITIONAL AUX. LIMIT SWITCHES	ADDITIONAL AUX. TORQUE SWITCHES	WIRING DIAGRAM NUMBER
1	Modulating	NO	YES	NO	NO	NO	WD-000641
1	Modulating	YES	YES	NO	NO	NO	WD-000636
2 - 5	Modulating	NO	YES	NO	NO	NO	WD-000645
2 - 5	Modulating	YES	YES	NO	NO	NO	WD-000623

NOTES:

1. Table is showing basic wiring diagram numbers for on/off and Modulating with or without a local control station.
2. For all other possible configuration wiring diagrams please see factory.

SINCE 1986, BRAY HAS PROVIDED FLOW CONTROL SOLUTIONS FOR A VARIETY OF INDUSTRIES AROUND THE WORLD.

VISIT **BRAY.COM** TO LEARN MORE ABOUT BRAY PRODUCTS AND LOCATIONS NEAR YOU.

HEADQUARTERS

Bray International, Inc.

13333 Westland East Blvd.

Houston, Texas 77041

Tel: +1.281.894.5454

All statements, technical information, and recommendations in this bulletin are for general use only. Consult Bray representatives or factory for the specific requirements and material selection for your intended application. The right to change or modify product design or product without prior notice is reserved. Patents issued and applied for worldwide. Bray® is a registered trademark of Bray International, Inc.

© 2024 BRAY INTERNATIONAL, INC. ALL RIGHTS RESERVED. BRAY.COM

EN_TSM_S76_Electric Actuator_20240528



THE HIGH PERFORMANCE COMPANY

BRAY.COM