

**RITE® SERIES 205
SINGLE DOOR WAFER TYPE SWING CHECK VALVE
SEAT RING HARD SEAT**



OVERVIEW

The Rite® Series 205 wafer combination swing check valves are flow activated and Rite® sized. The Rite® Series Check Valve inlet ports and disc have been shape optimized to achieve a fully open position at low flow rates (3 ft/s on average).

SPECIFICATIONS

| | |
|---------------------------|--|
| Size Range | NPS 2" to 48" 50mm to 1200mm |
| Temperature Range | Cryogenic to High Temperature (Pending Materials Selected) |
| Operating Pressure | ASME (150, 300, 600, 900, 1500) DIN (PN10, 16, 25, 40, 64, 100, 150, 250) |
| Body Style | One-Piece Wafer Body Seat Ring Type |
| Leakage Rate | API 598 |

APPLICATIONS

- > Chemical Processing
- > Electrolysis
- > Facilities/Skid
- > HVAC
- > Marine
- > Nuclear
- > Oil Transport
- > Petrochemical
- > Power Generation
- > Refrigeration
- > Storage & Transport
- > Tank Trucks
- > Water

MEDIA

- > Acids
- > Alkalis
- > Corrosive Chemicals
- > Dry Chlorine (Gas or Liquid)
- > Gases
- > Hydrogen
- > Oxygen
- > Water

DESIGN FEATURES

The Series 205 hard seated check valves offer:

SINGLE DOOR DESIGN:

Below numbered list can be referenced on various figures throughout document.

- 1** Combination design utilizing both gravity + spring makes the valve easy to open/close, reducing water hammer.
- 2** Limited movement of internal parts during operation extends service life.
- 3** Elliptical inlet shape designed to accelerate line media through the valve.
- 4** Optimal diameter for high flow capacity.
- 5** Short face to face, reducing weight and space between flanges.
- 6** Low cracking pressure design.
- 7** Quick response time (ideal for process lines with varying flows & control valves).
- 8** Customizable modular design, allows for adding optional special accessories to meet customer application requirements.
- 9** Cost & energy efficiency, requiring only one set of flange studs which span the valve, reducing in-service vibration.
- 10** Higher grade material as standard on seat ring type design enhances life expectancy.

Figure 01: Seat Ring Hard Seat Cutaway Front View.

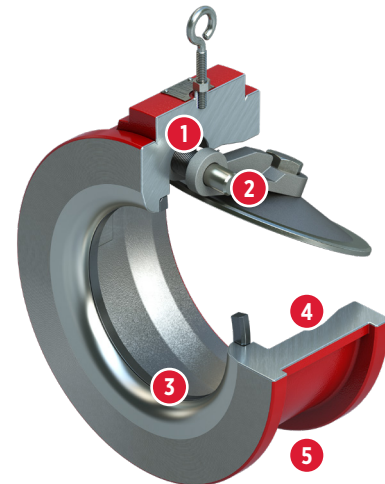
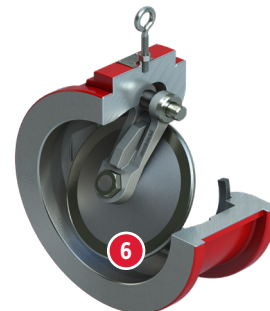

Figure 02: Seat Ring Hard Seat Cutaway Rear View.



RITE® SERIES 205
SINGLE DOOR WAFER TYPE SWING CHECK VALVE
SEAT RING HARD SEAT



DESIGN STANDARDS

| | |
|------------------------------|---|
| Valve Design | API 594 |
| Accessories Available | H100, SA01, SA1, SA2, SA3, SA4, SA4A, SA6, SA7, SA10, SA16, SA40, SA40A, SA50, SA54, etc. |
| Testing Standard | ASME B16.34, API 598 |
| Face-to-Face | API 594 |

CERTIFICATIONS AND APPROVALS

| | |
|-----------------------|--|
| Certifications | API 6FD (Carbon Steel Body) CE/PED CRN |
| Approvals | NSF-61 |

Additional information is available in the Bray Rite® Ltd. Technical Sales Manual.

Figure 03: Seat Ring Hard Seat Exploded View.

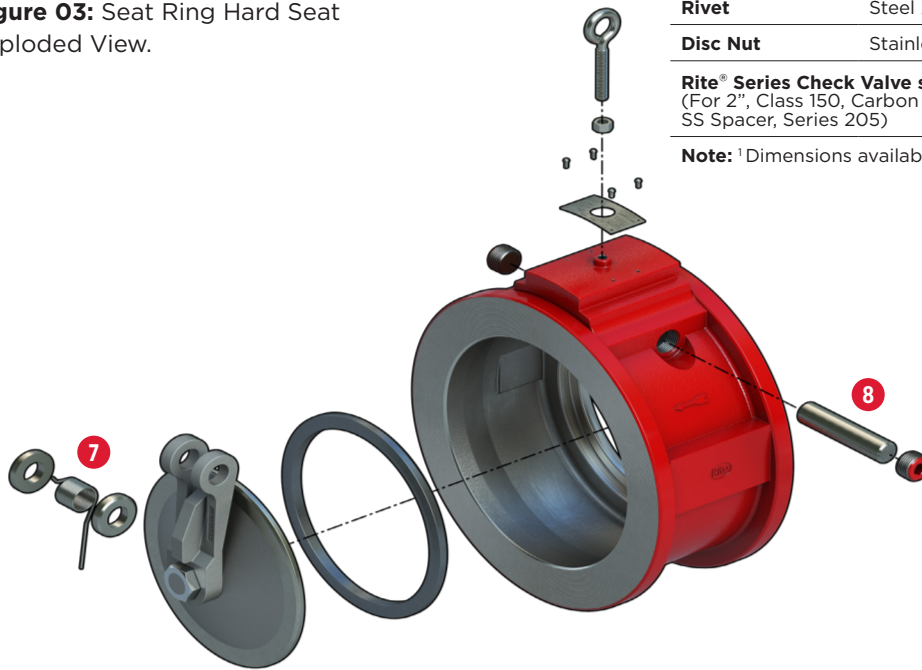

MATERIAL OPTIONS¹

Body Material determines whether design is integral type, or seat ring type. See below chart:

| | |
|------------------|---|
| Body | Carbon Steel (ASTM A216 WCB) Cast Iron (ASTM A126 CLB) Ductile Iron (ASTM A395) |
| Hinge | Stainless Steel (ASTM A351 CF8M) |
| Seat Ring | Stainless Steel (ASTM A240 304), Stellite overlay optional |
| Spring | Valve size: ≤12": Stainless Steel (ASTM A313 316) standard duty Valve size: ≥14"+: Stainless Steel (ASTM A313 17-7 PH) |
| Spacer | Stainless Steel (ASTM A479 316), PTFE optional |
| Pin | Stainless Steel (ASTM A479 316) |
| Plug | Steel |
| Lock Nut | Steel Zinc Plated |
| Eye Bolt | Steel Zinc Plated |
| Nameplate | Stainless Steel (SS 316) |
| Disc | Stainless Steel (ASTM A351 CF8M) |
| Rivet | Steel Zinc Plated |
| Disc Nut | Stainless Steel (ASTM F594 316) |

Rite® Series Check Valve seat ring type part number: V0215SMZ (For 2", Class 150, Carbon Steel ASTM A216 WCB Body, Metal Seat, SS Spacer, Series 205)

Note: ¹Dimensions available in ASME and DIN sizes.

Figure 04: Seat Ring Hard Seat In-Pipe View.

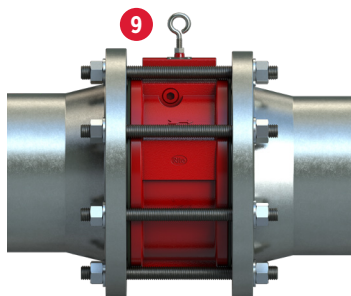

Figure 05: Seat Ring Hard Seat Close-Up Cutaway Views.

